

# Pneumatic Actuators with Rotary Lever Type 3204-1 and Type 3204-7



## Application

Pneumatic spring-and-diaphragm actuator for final control elements with rotary closure members; especially suitable for butterfly valves and louvers (shutters).

The Type 3204-1 and Type 3204-7 Pneumatic Actuators with Rotary Lever essentially consist of a Type 3271 or Type 3277 Pneumatic Actuator and a yoke with attached rotary lever (arm). These actuators contain a rolling diaphragm and installed compression springs (see Data Sheet T 8310-1 EN for actuator details).

## Special features

- Low overall height
- High positioning forces
- Fast speeds of response
- A wide variety of bench ranges that can be changed by varying the number of compression springs (3 to 12) and the compression of the installed springs.
- No special tools required to reverse the actuator action (operating direction) or to modify the bench range
- Maintenance-free joints with plain bearing free of non-ferrous metal

Attachment of pneumatic or electropneumatic positioners, solenoid valves and limit switches according to IEC 60534-6 and NAMUR recommendation. Type 3204-7 also suitable for integrated positioner attachment (see Data Sheet T 8355 EN for details).

## Versions

With effective diaphragm areas of 350 or 700 cm<sup>2</sup>

**Type 3204-1 · Pneumatic Actuator with rotary lever** (Fig. 1)

**Type 3204-7 · Pneumatic Actuator with rotary lever** (Fig. 2)  
for integral positioner attachment

## Additional versions available with

- Top-mounted handwheel



Fig. 1 · Type 3204-1 Pneumatic Actuator with Rotary Lever



Fig. 2 · Type 3204-7 Pneumatic Actuator with Rotary Lever

### Principle of operation (Fig. 3)

The signal pressure  $p_{st}$ , which is introduced as loading pressure to the diaphragm case, exerts a force onto the surface of the diaphragm (2). This force is balanced by the springs (4) arranged in the actuator. In this case, the number of actuator springs and their compression determine the bench range (signal pressure range). The position of the actuator stem (7) is transmitted to the actuator lever (12) via the components (8), (9) and (10). The lever is rotatable via a pivot in the yoke (11). It has three holes at the free end for fastening the forkhead with pin and locking washer.

Selection of the hole depends on the positioning force and the travel necessary for the connected linkage required.

The operating direction of the actuator stem (7) depends on how the springs are arranged and to which diaphragm case the loading pressure is connected (Fig. 3).

### Fail-safe action

#### Actuator stem extends (marked FA on the actuator)

The spring force moves the actuator stem downwards. In this case, the **loading pressure** is connected to the **bottom** diaphragm case.

#### Actuator stem retracts (marked FE on the actuator)

The spring force moves the actuator stem upwards. In this case, the **loading pressure** is connected to the **top** diaphragm case.

Table 1 · Technical data

Max. permissible supply pressure	6 bar
Permissible temperatures in continuous duty	Standard material NBR: -35 to +90 °C
	Special material for air free of oil and grease EPDM: -35 to +120 °C
<b>Materials</b>	
Rolling diaphragm	NBR (nitrile rubber) with fabric insert
	EPDM with fabric insert
Actuator stem	1.4305
Sealing of the actuator stem	NBR (nitrile rubber)
	EPDM
Diaphragm cases	Sheet steel, plastic coated
Yoke and rotary lever	EN-JS1030 (formerly GGG-40)
Linear shaft	1.4006

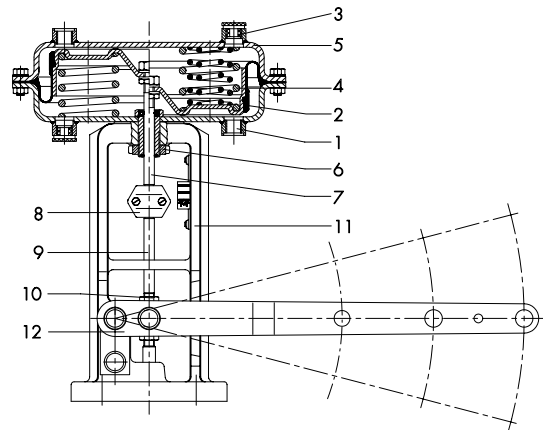

Fig. 3 · Sectional drawing of the Type 3204-1 Pneumatic Actuator with Rotary Lever (right half of diaphragm case with multiple springs)

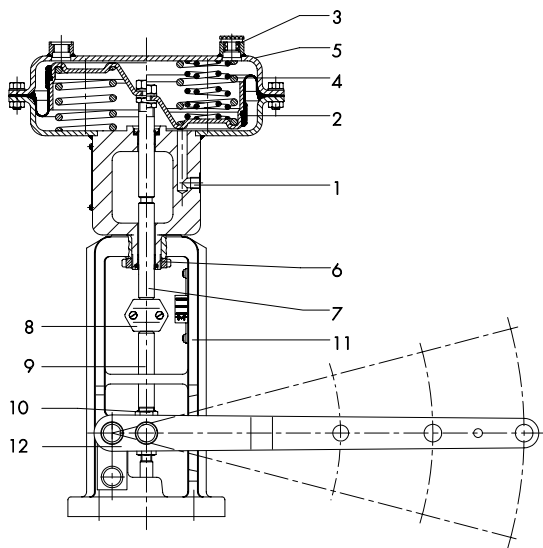

Fig. 4 · Sectional drawing of the Type 3204-7 Pneumatic Actuator with Rotary Lever

- |                               |  |
|-------------------------------|--|
| 1 Loading pressure connection | 7 Actuator stem                        |
| 2 Rolling diaphragm           | 8 Stem connector with travel indicator |
| 3 Vent                        | 9 Linear shaft                         |
| 4 Actuator springs            | 10 Adjustable coupling                 |
| 5 Diaphragm cases             | 11 Yoke                                |
| 6 Clamp nut                   | 12 Actuator lever (arm)                |

**Table 2 · Bench ranges and nominal forces**

All pressure in bar (gauge) · All forces in Nm

The forces specified represent the minimum forces at 0 % travel and  $p_{st} = 0$  bar.

The shaded columns of the table correspond to the standard bench range. Values in the white columns apply to max. pretensioned springs.

Bench range		0.2 to 1	0.4 to 1.2	0.4 to 2	0.8 to 2.4	0.6 to 3	1.2 to 3.6*	1.4 to 2.3	2.1 to 3.3
Req. supply pressure		1.2	1.6	2.4	3.2	3.6	4.8	3.7	5.4
Effective diaphragm area 350 cm <sup>2</sup> , rated travel 15 mm									
Force N	F 1	100	200	200	400	300	600	700	1050
	F 2	71	140	140	280	210	420	500	750
	F 3	55	110	110	220	160	330	380	580
Effective diaphragm area 700 cm <sup>2</sup> , rated travel 30 mm									
Force N	F 1	230	470	470	950	710	1420	1660	2500
	F 2	190	380	380	760	570	1140	1330	2000
	F 3	150	310	310	630	470	950	1110	1670

\* Fail-safe action version: Actuator stem extends only  
Positioners are recommended for the bench ranges 0.2 to 1 bar. They are required in all other cases.

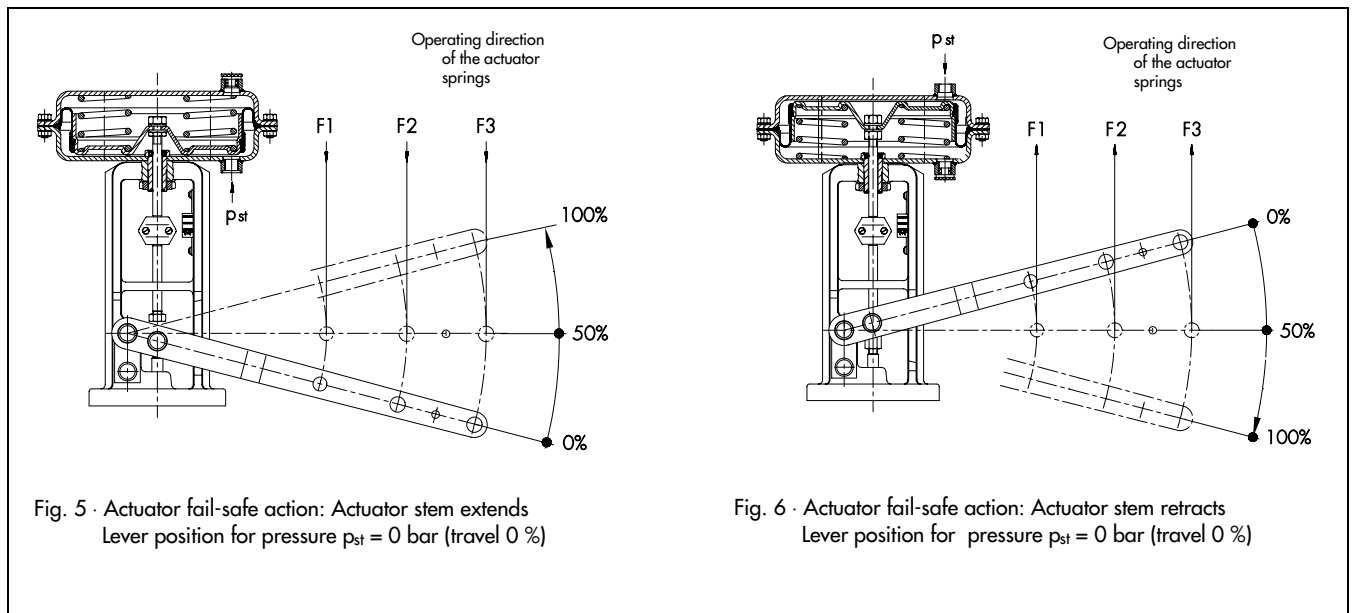

**Table 3 · Dimensions in mm and weights in kg for Type 3204-1**

Actuator cm <sup>2</sup>	Rated travel	D	H1 <sup>1)</sup>	H2	A	B	C	s1	s2	s3	d1	α1 [°]	α2 [°]	Weight <sup>1)</sup>
350	15	280	383	85	198	292	385	100	140	180	16.2	25	26	20
700	30	390	484	120	217	283	350	160	200	240	20.2	35	14	38

<sup>1)</sup> With Type 3204-7 Pneumatic Actuator with Rotary Lever, add 100 mm to H1 and 2 kg to the weight

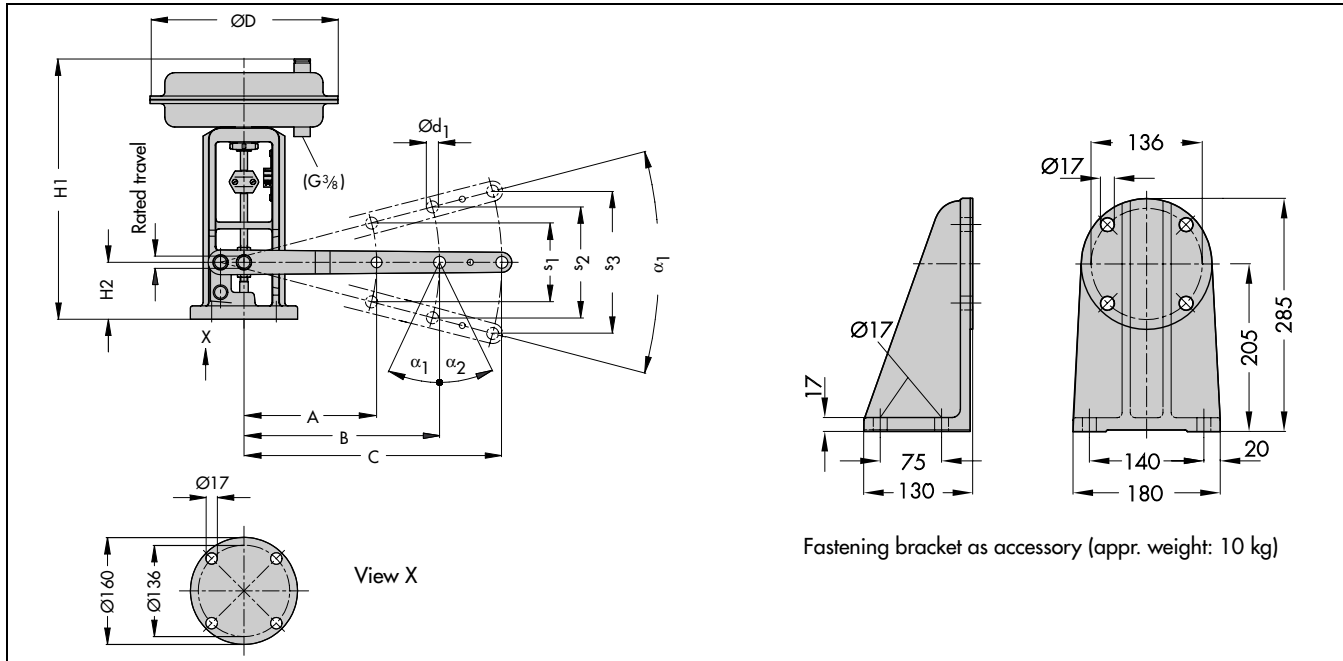

**Table 4 · Forkhead with pin and locking washer**

Dimensions in mm and weights in kg

Version	L1	L2, L3 L5	L4	L6	D1	D2	D3	Appr. weight kg
350 cm <sup>2</sup>	83	32	64	24	26	16 H8	M16	0.3
700 cm <sup>2</sup>	105	40	80	30	34	20 H8	M20	0.5

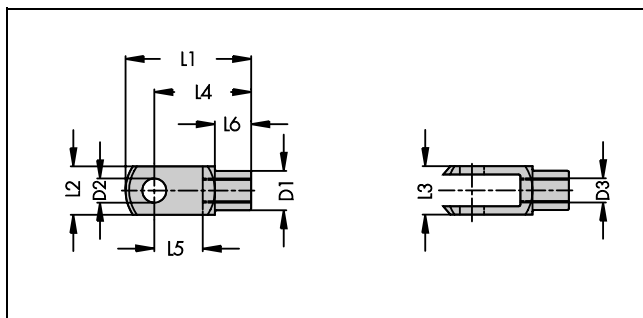

**Ordering text**

Pneumatic Actuator  
with Rotary Lever

Effective diaphragm area  
Bench range  
Operating direction  
Rolling diaphragm  
Optional accessories

Optional special version  
Accessories

- Positioner
- Solenoid valve
- Limit switch

Type 204-1/-7,  
with/without handwheel

... cm<sup>2</sup>  
... bar  
Actuator stem retracts/extends  
NBR/EPDM  
Fastening bracket  
Forkhead

Specifications subject to change without notice.

