

Pneumatic Transmitter for Pressure Type 804-1



Application

Pressure transmitter for pneumatic measuring and control systems with operating pressures from -1 bar to 150 bar

The pressure transmitters are suitable for liquids, gases and vapors. They measure pressures and convert the measured value into a pneumatic output signal from 0.2 bar to 1.0 bar. The devices are designed according to the modular principle and comprise a transmitter, which operates according to the force-balance method, as well as easy-to-replace measuring elements.

Special features

- The exchangeable measuring elements (Fig. 3) permit the use of the transmitters for measuring spans from 0.016 bar to 100 bar
- All components that come into contact with the process medium are made of stainless steel, even in the standard version
- Wide permissible ambient temperature range from -35 °C to $+120$ °C
- Measuring range adjustable over a spindle within a wide range; max. ratio 1:25
- High overload capability and wide range of application
- Easy-to-replace booster section comprising feedback bellows, nozzle and pneumatic booster; optionally free of non-ferrous metal
- Can be used in hazardous areas (Zone 1 and Zone 2) without restrictions nor special requirements

Versions

Type 804-1 standard version (Fig. 1) · Suitable for direct connection of the process medium · Lower range value $p_e = 0$ bar

Type 804-1 with adjustable lower range value · With additional spring for positive or negative adjustment of the lower range value · Transmitters for negative pressure measurement with lower range value of $p_e = -1$ bar available

Type 804-1 for oxygen · Measuring element with inner surfaces free of impurities

Type 804-1 free of non-ferrous metal · All parts free of copper

Further equipment from the Series 804-1:

Type 804-1 with pressure-transmitting sealing element · For special process media · Refer to Data Sheet T 7550 EN

Type 814 · Flanged pressure transmitter with measuring spans from $p_e = 0.016$ bar to 100 bar · Refer to Data Sheet T 7554 EN



Fig. 1 · Type 804-1 Pneumatic Transmitter for Pressure

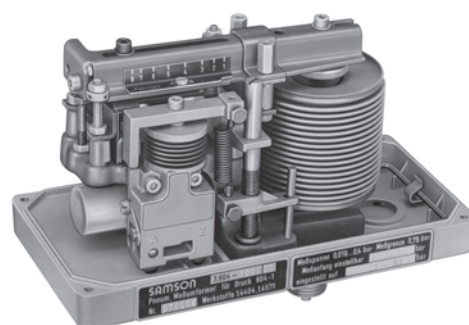

Fig. 2 · Type 804-1, front view with cover removed



Pressure measuring elements for max. measuring spans of
0.4 bar 6 or 20 bar 100 bar
metal bellows

Fig. 3 · Type 804-1, pressure measuring elements

Principle of operation (see Figs. 4, 5 and 6)

The pressure p of the medium measured by the measuring element (10) produces a force that acts on the primary beam (9). This force is transmitted to the secondary beam (7) over the adjustable span rider (4). The system is balanced when the input force and the force resulting from the output air pressure p_A and the surface area of the feedback bellows (2) are identical.

The supply air p_Z supplies the booster (17) and flows against the flapper (14) through the throttle (1) and the nozzle (15). When the medium pressure p increases, the primary beam (9) changes position and the flapper (14) moves closer to the nozzle (15). As a result, the cascade pressure supplied to the booster (17) as well as the output pressure p_A supplied to the feedback bellows (2) are increased. p_A increases until the force produced at the feedback bellows (2) and the force at the pressure measuring element (10) are the same and a new equilibrium has been established. When the pressure p inside the pressure measuring element (10) drops, the flapper (14) moves away from the nozzle (15) and both the cascade pressure and the output pressure p_A decrease until the system is balanced again. The pneumatic output signal p_A assumes a value proportional to that of the input pressure.

Due to the relay arrangement of the booster (17), the distance between the flapper (14) and the nozzle (15) in the force-balanced system is extremely small, i.e. practically zero. Therefore, the hysteresis of the pressure measuring element (10), the feedback bellows (2), the cross spring pivot of the primary beam (9) and the secondary beam (7) as well as the springs for zero and lower range value adjustment (8, 18) have almost no influence on the measuring characteristics of the transmitter.

After the locking screw (5) has been loosened, the span rider (4) can be moved by turning the spindle (3), and the transmission ratio between the measuring element (10) and the feedback bellows (2), i.e. the measuring span, can be continuously adjusted. The ratio of the adjustable minimum span to the maximum adjustable span is 1:25 in transmitters with a bellows measuring element.

Zero can be adjusted on the adjusting screw (8) without having to remove the cover.

The additional spring (18) is used to adjust the lower range value. Versions fitted with a particular spring permit the continuous adjustment of the lower range value to positive effective pressures. Selecting a different spring version allows the transmitter to be used for negative pressure measurement, e.g. lower range value $p_e = -1$ bar, as well.

Legend for Figs. 4, 5 and 6

- 1 Throttle
- 2 Feedback bellows
- 3 Spindle with hexagon screw
- 4 Span rider
- 5 Locking screw
- 6 Scale for preadjusting the measuring span
- 7 Secondary beam
- 8 Zero adjusting screw
- 9 Primary beam
- 10 Pressure measuring element
- 11 Base
- 12 Process medium connection (input = "E")
- 13 Rail
- 14 Flapper
- 15 Nozzle
- 16 Volume
- 17 Booster
- 18 Spring for shifting the lower range value
- 19 Nuts for adding or removing tension from spring (18)
- 20 Booster section

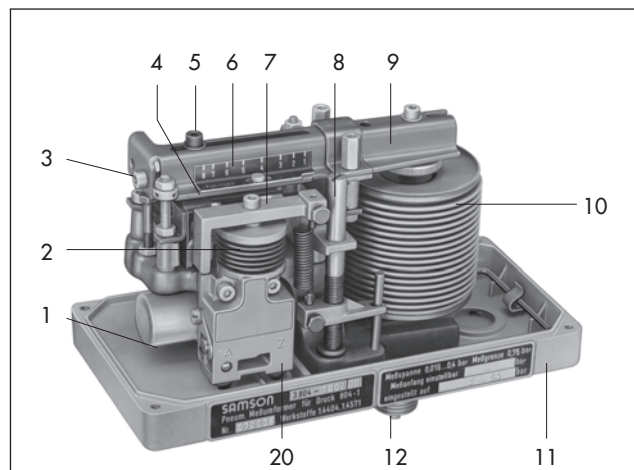

Fig. 4 · Front view, standard version without cover

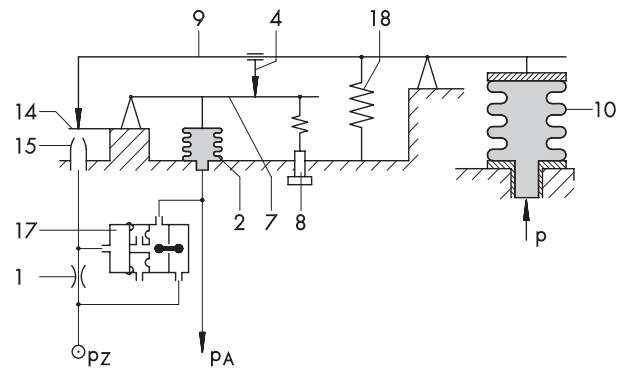

Fig. 5 · Functional diagram

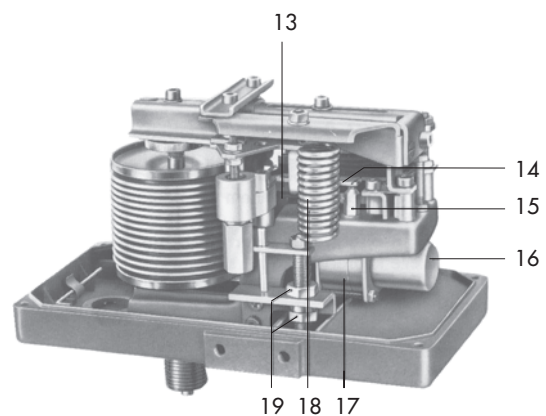

Fig. 6 · Rear view without cover, transmitter with spring for adjustable lower range value

Table 1 · Technical data · All pressures p_e given in bar (gauge) unless specified otherwise

Type	804-1			
Measuring span continuously adjustable	0.016 to 0.4 bar	0.25 to 6 bar	0.8 to 20 bar	4 to 100 bar
Upper range value	0.76 bar	11.4 bar	38 bar	150 bar
Can be overloaded up to	Ten times the adjusted measuring span, however not exceeding			
	1.5 bar	25 bar	50 bar	200 bar
Ultimate strength up to	8 bar	60 bar	100 bar	250 bar
Pressure measuring element	Metal bellows			
Volume of the pressure measuring element	115 cm ³	12 cm ³	6.4 cm ³	4.7 cm ³
Supply air	1.4 ± 0.1 bar (20 ± 1.5 psi), air quality according to ISO 8573-1 Edition 2001: particle size and amounts: Class 4, oil content: Class 3, pressure dew point: Class 3 or at least 10 K below the lowest ambient temperature to be expected			
Output pressure	0.2 to 1 bar (3 to 15 psi possible)			
Permissible ambient temperature	-35 °C to +120 °C, lower temperatures on request			
Permissible storage temperature	-50 °C to +120 °C			
Air consumption in steady state	< 0.15 m _n ³ /h			
Max. air delivery	1 m _n ³ /h			
Load characteristic	0.3 m _n ³ /h per 3 % change of the output signal			
Characteristic	Linear			
Deviation from linearity	< 0.5 % (1 %) with fixed set point ¹⁾			
Hysteresis	< 0.5 % (0.4 %), for measuring spans up to approx. 0.06 bar: < 0.3 % (0.6 %) ¹⁾			
Dead band	< 0.05 %			
Temperature influence	< 0.03 %/°K (for -20 °C to +120 °C)			
Supply air influence ± 0.1 bar	For measuring spans 1 to 3: < 0.4 %/0.1 bar pressure change For positions on the scale (6) 4 to 8: < 0.25 %/0.1 bar pressure change			
Overload influence	Overload to permissible value < 1 %			
Degree of protection	IP 54			
Transmitter with adjustable lower range value				
Lower range value adjustable between ... bar	-0.36 and -0.04	-1 and -0.6	-	-
	-0.04 and 0.04	-0.6 and 0.6	-1 and 2	-1 and 10
	0.04 and 0.36	0.6 and 5.4	2 and 18	10 and 90
Additional temperature influence when the lower range value is shifted by up to ten times the measuring span: < 0.05 %/°K				

¹⁾ Values in parentheses apply to ± measurement

Table 2 · Materials · Material numbers according to DIN EN

Metal bellows	1.4404
Connection nipple	1.4571
Spring band	1.4310
Span rider and rail	1.4034, hardened
Beam	Steel, chromated
Booster and volume	Aluminum, chromated
Booster gasket	Silicone rubber
O-rings	FPM / FKM
Base and cover	Die-cast aluminum, plastic coated
Weight, approx.	2.7 kg

Installation

The usual mounting position, i.e. with the base in horizontal position and the process medium connection pointing downward, is shown in the dimensional drawings below.

The transmitter can also be installed with the base in vertical and the process medium connection in horizontal position. In this mounting position, the air connections must be located above the process medium connection. Zero must be corrected when this mounting position is used.

Dimensions in mm

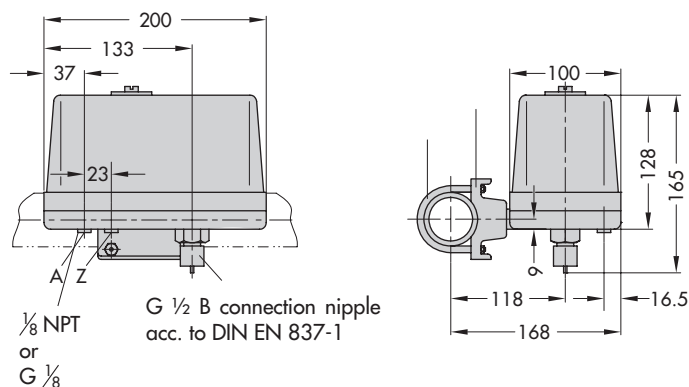

Fig. 7 · Dimensions and mounting methods

Air connections: two $\frac{1}{8}$ NPT threaded bores (optionally, two $G \frac{1}{8}$ threaded bores according to ISO 228)

Process medium connection

Metal bellows measuring element: connection nipple with $G \frac{1}{2}$ B cylindrical pipe thread according to DIN EN 837-1

Accessories

Screw fittings, shut-off valves, supply pressure reducing stations etc.

Ordering text

Type 804-1 Transmitter

Measuring span ... bar

Standard version / version with adjustable lower range value / version free of non-ferrous metal

Measuring span ... bar

For versions with adjustable lower range value: lower range value adjustable from ... to ... bar, adjusted to ... to ... bar

Output 0.2 bar to 1 bar / 3 to 15 psi

Optionally, special version ...

Optionally, accessories ...

Specifications subject to change without notice.

