

Electropneumatic Converter for Direct Current Signals

i/p Converter Type 3913-0001



Application

Devices used to convert a direct current signal into a pneumatic signal for measurement and control. Especially suitable as intermediate element between electric measuring devices and pneumatic controllers, or between electric control devices and pneumatic control valves.



The converter input accepts a load-independent 0 to 20 mA direct current signal.

Depending on the supply air pressure, the converter provides a pneumatic output signal of 0.1 to 4 bar (1.5 to 60 psi).

Special features

- Small dimensions, low weight and rugged housing
- Excellent dynamic response
- Relatively large air output with low air supply consumption
- Output pressure up to 4 bar
- Central venting
- Low vibration effect
- Option of connecting a pressure gauge parallel to the output
- Operation possible without upstream pressure regulator

Versions

For use in **safe areas**:

- **Type 3913-0001**, without electronics, ¼ - 18 NPT
- **Type 3913-0001**, without electronics, ISO-228/1-G ¼



Fig. 1 · Type 3913-0001 i/p Converter with pressure gauge

Principle of operation

The electropneumatic converter consists of an i/p module which operates according to the principle of force equilibrium and a downstream volume booster.

When operated, the supplied direct current (4) flows through the plunger coil (2) located in the field of a permanent magnet (3). At the balance beam (1), the force of the plunger coil, which is proportional to the current, is balanced against the force of the dynamic back-pressure.

The back-pressure is produced on the flapper plate (6) by the air jet leaving the nozzle (7). The air supply (8) flows into the lower chamber of the volume booster. A certain amount of air determined by the position of the diaphragm reaches the sleeve (9) and flows to the output (36).

When the input current increases and, as a result, the force of the plunger coil increases as well, the flapper moves closer to the nozzle. This causes the dynamic back-pressure and the cascade pressure p_K forming upstream of the restrictor (8.2) to increase. The cascade pressure increases until it corresponds to the input current and pushes both the diaphragm (10) and the sleeve (9) downwards, causing the output pressure p_A to increase until a new state of equilibrium is reached in the diaphragm chambers. When the cascade pressure decreases, the diaphragm is pressed upwards and it releases the sleeve. The output pressure p_A escapes through the sleeve to the vent (EXHAUST) until the forces on the diaphragm are balanced again.

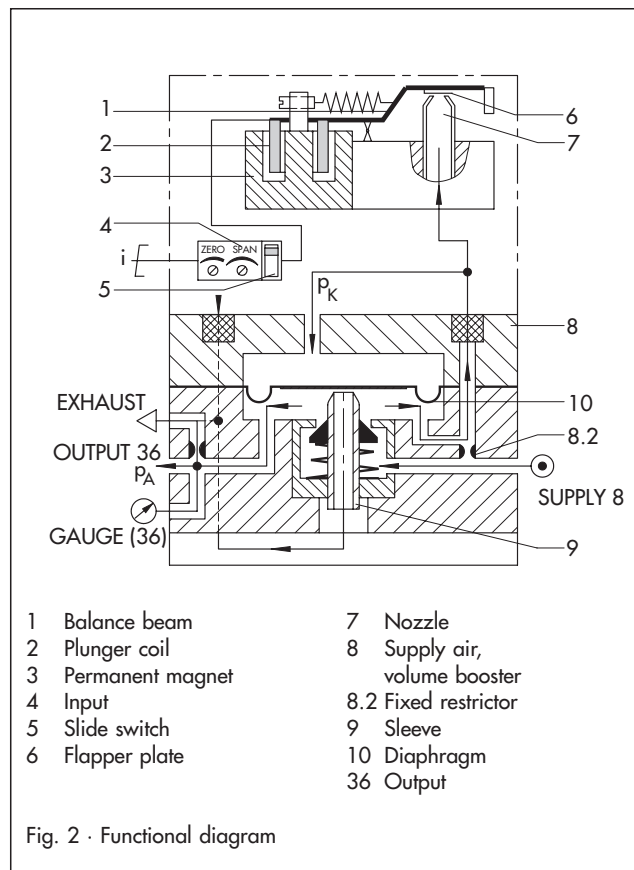
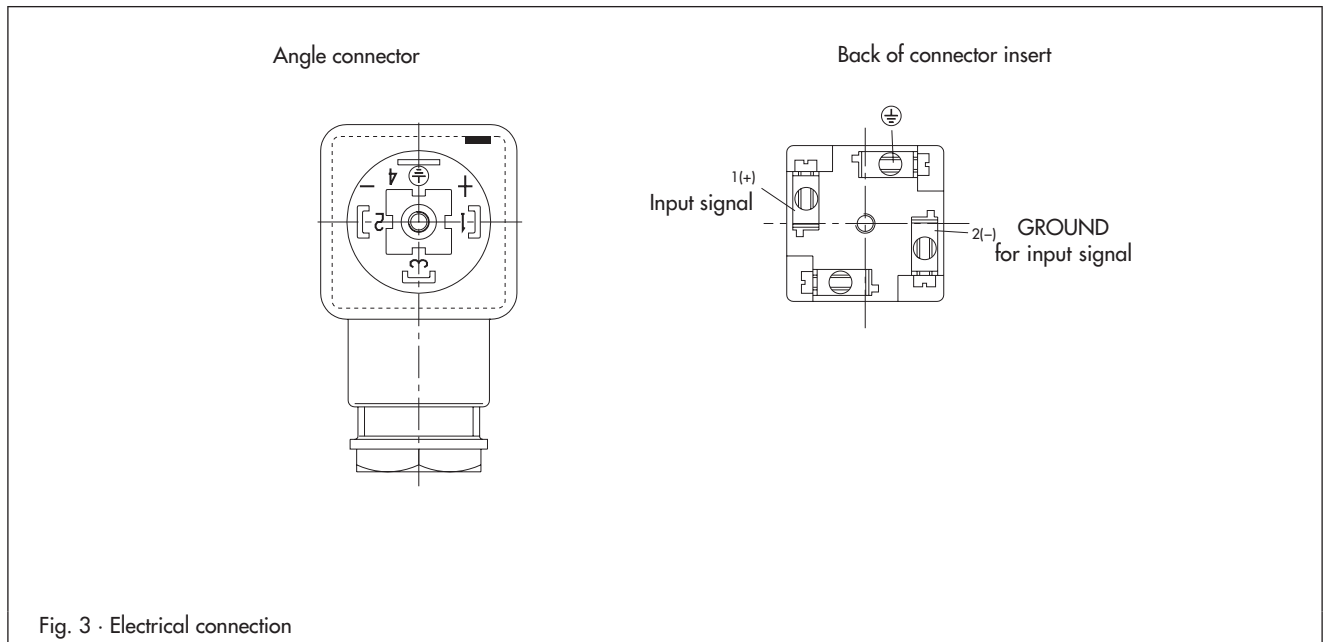

Table 1 · Technical data

Type	w/o explosion protection	Type 3913-0001
Input		0 to 20 mA Minimum current > 3.6 mA Load ≤ 6 V (corresponds to 300 Ω at 20 mA)
Output		0.1 to 4 bar (1.5 to 60 psi)
	Air output capacity ¹⁾	2.0 m ³ /h at 0.6 bar output (8.7 psi) 2.5 m ³ /h at 1.2 bar output (17.4 psi)
Supply air		Min. 0.4 bar (5.8 psi) above upper pressure range value, max. 4.5 bar (65 psi) without upstream pressure regulator
	Air consumption ²⁾	0.08 m ³ /h at 1.4 bar (20 psi) 0.1 m ³ /h at 2.4 bar (35 psi)
Performance		Characteristic: Output linear to input
	Hysteresis	≤ 0.3 % of final value; more accurate values on request
	Deviation from terminal-based conformity	≤ 1 % of final value; more accurate values on request
	Effect in % of final value	Supply air: 0.1 %/0.1 bar ²⁾
		Alternating load, supply air failure, interruption of input current: < 0.3 %
		Ambient temperature: Lower range value < 0.02 %/°C, measuring span < 0.03 %/°C
Dynamic response (measured according to IEC 60770-1)		
	Limiting frequency	5.3 Hz
	Phase shift	-130°
Effect of variable mounting position Max. 1 % depending on how the device is mounted; ±0.3 % in horizontal position		
Ambient conditions, degree of protection, weight		
Ambient temperature		-25 to +70 °C
Degree of protection		IP 65 (IEC 60529)
Weight		Approx. 0.6 kg
Materials		
Housing		Die-cast aluminum, chromated, plastic-coated/glass fiber reinforced polyamide
Other parts		Corrosion-resistant material

¹⁾ Measured with 2 m hose 4 x 1 · ²⁾ Measured at average output pressure

Electrical connection



Dimensions in mm

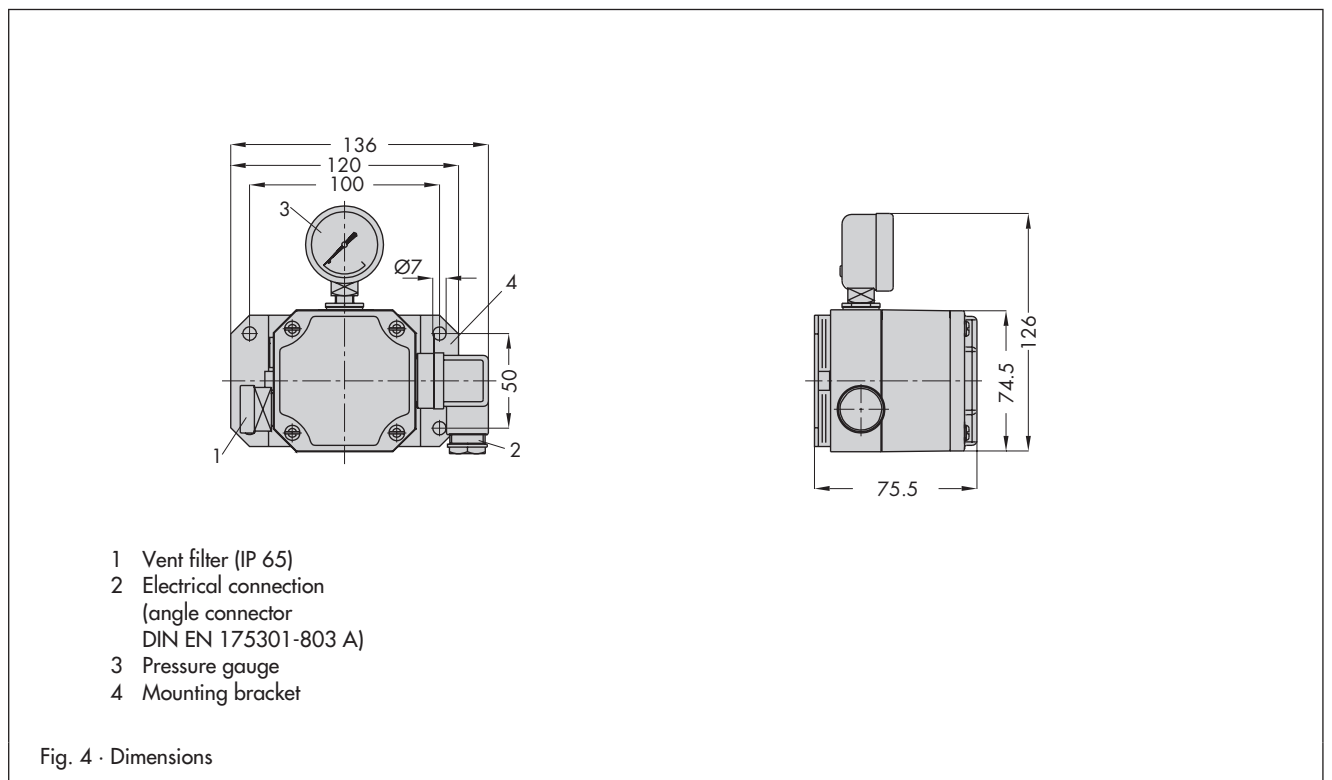

Installation

The device must be installed in a horizontal position with the pressure gauge (or screw plug) facing upwards.

Ordering text

i/p Converter Type 3913-0001-0122010110000
without electronics, 1/4 - 18 NPT

i/p Converter Type 3913-0001-0222010110000
without electronics, ISO-228/1-G 1/4

Specifications subject to change without notice.

SAMSOMATIC GMBH

A company of the SAMSON Group

Weismüllerstraße 20–22
60314 Frankfurt am Main
Germany

Phone: +49 69 4009-0
Fax: +49 69 4009-1644
E-mail: samsomatic@samson.de
Internet: <http://www.samsomatic.de>

2007-10