

# Self-operated Pressure Regulators

## Type 2422/2424 · Version as Pressure Reducing Valve



### ANSI version

#### Application

Pressure regulators for set points from **0.75 to 35 psi** (0.05 to 25 bar) · Valves in **NPS 6 to NPS 10** (DN 150 to DN 250) Pressure rating **Class 125 to 300** · Suitable for water, gases and vapors up to **+660 °F** (350 °C)

The valve **closes** when the downstream pressure **rises**



The pressure reducing valves consisting of a valve and an actuator control the pressure downstream of the valve to an adjustable set point. The medium pressure to be kept constant is transmitted over a control line to the diaphragm of the actuator and the valve plug.

#### Special features

- Low-maintenance proportional regulators requiring no auxiliary energy
- Wide set point range and easy set point adjustment over a nut
- Exchangeable actuator and positioning springs
- Spring-loaded, single-seated valve with upstream and downstream pressure balancing by a stainless steel bellows
- Low-noise standard plug · Special version with a flow divider St I for further noise level reduction (see Data Sheet T 8081 EN)

#### Versions

**Type 2422/2424** · Pressure Reducing Valve in sizes NPS 6 to NPS 10 (DN 150 to 250) consisting of:

**Type 2422** Valve with soft-seated plug, balanced by a bellows or a diaphragm · Body of cast iron A 126 B, carbon steel A 216 WCC or stainless carbon steel A 351 CF8M

**Type 2424** Actuator with EPDM rolling diaphragm and screw fitting

Refer to Data Sheet T 2650 EN for more details with Type 2422 Valve balanced by a diaphragm

#### Special versions

- Valve with flow divider St I for particularly low-noise operation with gases and vapors
- With metal-seated plug
- FPM rolling diaphragm for oils
- Version completely in stainless steel for pressure ratings Class 125 to 300 · Details on request
- Versions for oxygen service
- Actuator with two diaphragms



Fig. 1 · Type 2422/2424 Pressure Reducing Valve

### Principle of operation (Fig. 2)

The medium flows through the valve as indicated by the arrow. The position of the valve plug (3) and the area released between the plug and seat (2) determine the flow rate. The plug stem (5) with the plug is connected to the stem (11) of the actuator (10).

To control the pressure, the operating diaphragm is tensioned by the positioning springs (7) and the set point adjuster (6) so that the valve is opened by the force of the positioning springs when it is relieved of pressure ( $p_1 = p_2$ ).

The downstream pressure  $p_2$  to be controlled is tapped downstream of the valve and transmitted via the control line to the operating diaphragm (12) where it is converted into a positioning force. This force is used to move the valve plug (3) according to the force of the positioning springs (7), which is adjustable at the set point adjuster (6). When the force resulting from the downstream pressure  $p_2$  rises above the adjusted set point, the valve closes proportionally to the change in pressure.

The fully balanced valves are equipped with a balancing bellows (4.1). The downstream pressure  $p_2$  acts on the inside of the bellows, whereas the upstream pressure  $p_1$  acts on the outside of the bellows. As a result, the forces produced by the upstream and downstream pressures acting on the plug are balanced.

The valves can be equipped with a St I flow divider. When retrofitting the valve with a flow divider, the seat must be exchanged.

### Installation

- Install the valve with the actuator suspended downwards.
- Install pipelines horizontally with a slight downward slope on both sides of the valve for drainage of the condensate.
- The direction of medium flow must correspond with the arrow on the valve body.
- Connect a control line to the actuator from the point of pressure tapping in the pipeline located approximately 39" (1 meter) downstream of the valve or at the point of measurement of the connected plant (with condensation chamber, if necessary).

**Table 1** ·  $C_V$  and  $K_{VS}$  coefficients and  $z$  values

NPS	DN	Seat $\varnothing$		$C_{VS}$	$K_{VS}$	$C_V^I$	$K_{VS}^I$	$z^{1)}$
		inch	mm					
6	150	5	125	330	280	245	210	0.35
8	200	8.1	207	490	420	370	315	0.3
10	250	8.1	207	590	500	440	375	0.3

<sup>1)</sup> Terms for noise level calculation according to VDMA 24422 (edition 1.89)

$z$  · Acoustical valve coefficient

$C_{VS}^I$ ,  $C_V$ ,  $K_{VS}^I$ ,  $K_{VS}$  · For installation of a flow divider St I as a noise-reducing component · Flow characteristic differences between valves with and valves without flow dividers do not occur until the valve has passed through approx. 80 % of its travel range.

**Terms for control valve sizing** according to DIN EN 60534, Parts 2-1 and 2-2:

$$F_L = 0.95 \quad X_T = 0.75$$

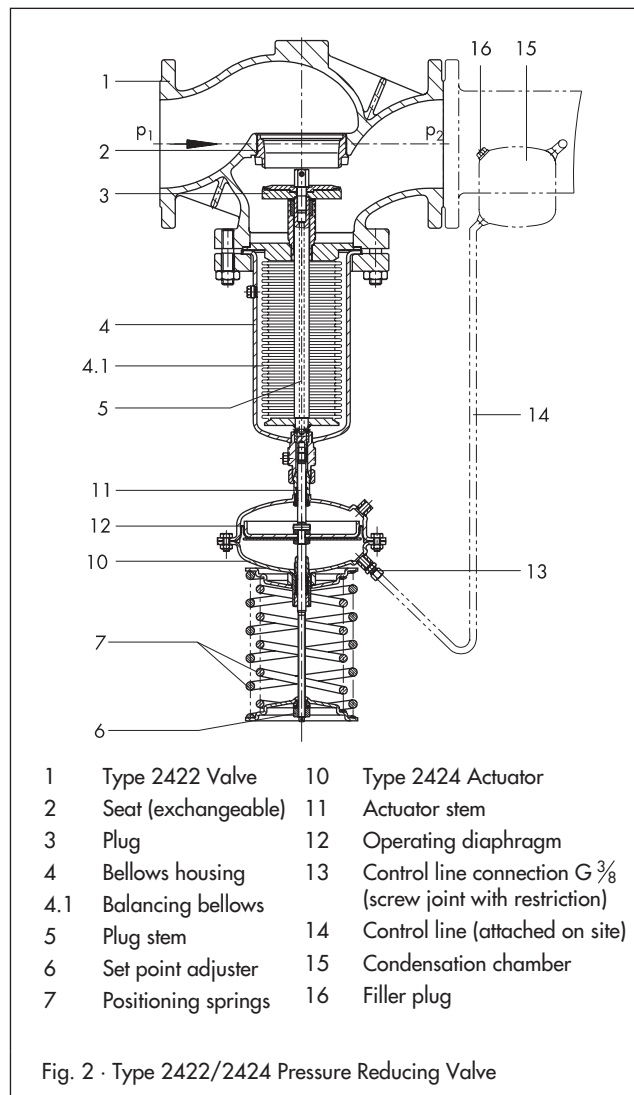

Fig. 2 · Type 2422/2424 Pressure Reducing Valve

### Valve-specific correction terms

$\Delta_{LG}$  · For gases and vapors:

Values as specified in the diagram in Fig. 3

$\Delta_{LF}$  · For liquids:

$$\Delta_{LF} = -10 \cdot (X_F - z) \cdot y \quad \text{with } X_F = \frac{\Delta p}{p_1 - p_v} \quad \text{and } y = \frac{K_v}{K_{VS}}$$

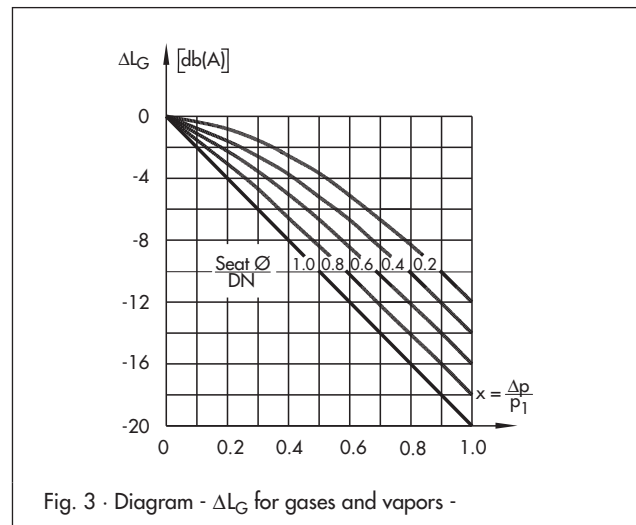

Fig. 3 · Diagram -  $\Delta_{LG}$  for gases and vapors -

**Table 2 · Technical data** · All pressures as gauge pressure

Type 2422 Valve		NPS 6 · DN 150	NPS 8 and 10 · DN 200 and 250
Nominal size			
Pressure rating		Class 125, 150 or 300	
Max. permissible differential pressure		175 psi · 12 bar	145 psi · 10 bar
	Valve plug	See Fig. 4 · Pressure-temperature diagram	
Temperature range	Soft sealing	Max. 430 °F (220 °C) with PTFE soft sealing · Max. 300 °F (150 °C) with EPDM soft sealing	
	Metal sealing	Max. 660 °F (350 °C) with body in A 216 WCC · Max. 450 °F (230 °C) with body in A 126 B	
Leakage rate		Metal sealing: Leakage rate I ≤ 0.05 % of C <sub>V</sub> or K <sub>VS</sub> · Soft sealing: Leakage rate IV	
Type 2424 Actuator			
Set point ranges		0.75 to 3.5 psi · 1.5 to 8.5 psi · 3 to 15 psi · 7 to 20 psi · 15 to 35 psi	
		0.05 to 0.25 bar · 0.1 to 0.6 bar · 0.2 to 1 bar · 0.5 to 1.5 bar · 1 to 2.5 bar	
Max. perm. pressure at actuator	Effective diaphragm area	50 in <sup>2</sup> · 320 cm <sup>2</sup>	100 in <sup>2</sup> · 640 cm <sup>2</sup>
	Pressure	43.5 psi · 3 bar	22 psi · 1.5 bar
Max. permissible temperature		Gases: 175 °F (80 °C) at the actuator · Liquids: 300 °F (150 °C), with condensation chamber max. 660 °F (350 °C) · Steam with condensation chamber: max. 660 °F (350 °C)	

<sup>1)</sup> Special version

**Table 3 · Materials** · Material number according to ASTM and DIN EN

Type 2422 Valve			
Pressure rating	Class 125	Class 150/300	
Max. permissible temperature	450 °F · 230 °C	660 °F · 350 °C	
Body	Cast iron A 126 B	Carbon steel A 216 WCC	Stainless carbon steel A 351 CF8M
Seat		Stainless steel	Stainless steel
Plug		Stainless steel	Stainless steel
	Seal ring for soft seal	PTFE with 15 % glass fiber up to 430 °F (220 °C)	
Balancing bellows		Stainless steel 1.4571	
Seal ring		Graphite with metal core	
Type 2424 Actuator			
Diaphragm cases		Sheet steel DD 11	
Diaphragm <sup>1)</sup>		EPDM with fabric insert	
Guide bushing		DU bushing	
Gaskets		EPDM/PTFE <sup>1)</sup>	

<sup>1)</sup> Special version for oils: FPM (FKM)

**Pressure-temperature diagram** – Materials acc. to ASTM –

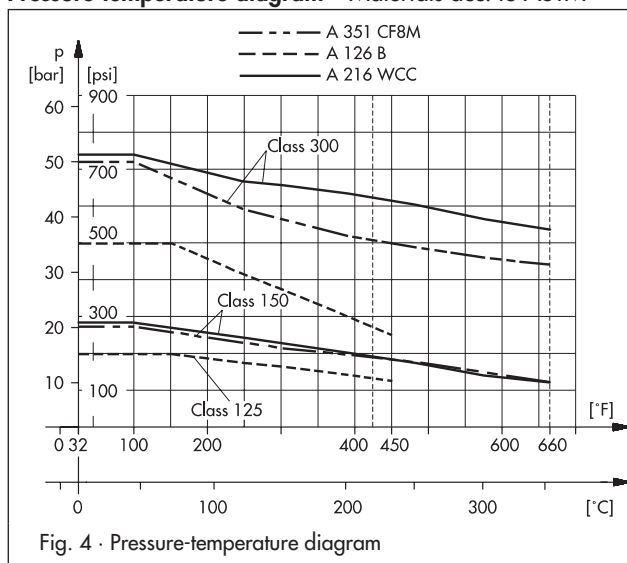

Fig. 4 · Pressure-temperature diagram

The range of application of the valves and the permissible pressures and temperatures are limited by the pressure-temperature diagram and the pressure ratings.

**Table 4 · Dimensions and weights** · Type 2422 Valve balanced by a bellows · Dimensions in parentheses apply to temperatures between 430 °F (220 °C) to 660 °F (350 °C)

Pressure rating					
Nominal size		NPS 6 · DN 150	NPS 8 · DN 200	NPS 10 · DN 250	
Set point range	Length L	Class 125/150	17.75" · 451 mm	21.4" · 543 mm	26.5" · 673 mm
		Class 300	18.6" · 473 mm	22.4" · 568 mm	27.9" · 708 mm
	Height H1	23.2" · 590 mm (28.4" · 730 mm)	28.7" · 730 mm (34.25" · 870 mm)	28.7" · 730 mm (34.25" · 870 mm)	
	Height H2, approx.	6.9" · 175 mm	9.25" · 235 mm	10.2" · 260 mm	
0.75 to 3.5 psi 0.05 to 0.25 bar	Height H	44" · 1120 mm (49.6" · 1260 mm)	49.6" · 1260 mm (55.1" · 1400 mm)		
	Actuator	∅ D = 15" · 380 mm, A = 100 in <sup>2</sup> · 640 cm <sup>2</sup>			
	Valve spring force F	2150 N			
1.5 to 8.5 psi 0.1 to 0.6 bar	Height H	44" · 1120 mm (49.6" · 1260 mm)	49.6" · 1260 mm (55.1" · 1400 mm)		
	Actuator	∅ D = 15" · 380 mm, A = 100 in <sup>2</sup> · 640 cm <sup>2</sup>			
	Valve spring force F	3600 N			
3 to 15 psi 0.2 to 1.0 bar	Height H	44" · 1120 mm (49.6" · 1260 mm)	49.6" · 1260 mm (55.1" · 1400 mm)		
	Actuator	∅ D = 15" · 380 mm, A = 100 in <sup>2</sup> · 640 cm <sup>2</sup>			
	Valve spring force F	8000 N			
7 to 20 psi 0.5 to 1.5 bar	Height H	40.9" · 1040 mm (46.4" · 1180 mm)	46.4" · 1180 mm (52" · 1320 mm)		
	Actuator	∅ D = 11.2" · 285 mm, A = 50 in <sup>2</sup> · 320 cm <sup>2</sup>			
	Valve spring force F	4600 N			
15 to 35 psi 1 to 2.5 bar	Height H	40.9" · 1040 mm (46.4" · 1180 mm)	46.4" · 1180 mm (52" · 1320 mm)		
	Actuator	∅ D = 11.2" · 285 mm, A = 50 in <sup>2</sup> · 320 cm <sup>2</sup>			
	Valve spring force F	8000 N			
Gewicht					
0.75 to 15 psi 0.05 to 1.0 bar	Weight for cast iron A 216 B, Class 125 <sup>1)</sup>	185 kg · 496 lb	425 kg · 1139 lb	485 kg · 1300 lb	
7 to 35 psi 0.5 to 2.5 bar		175 kg · 469 lb	415 kg · 1112 lb	475 kg · 1273 lb	

<sup>1)</sup> Class 150: +10 %; Class 300: +15 %

## Dimensions

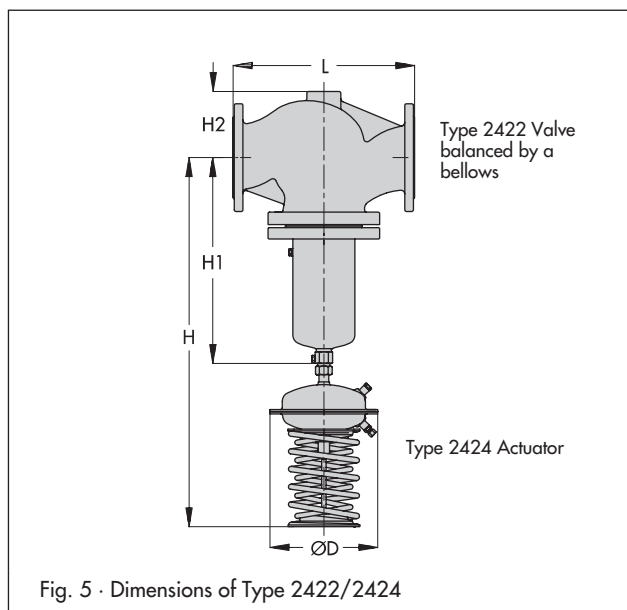

## Accessories

- Screw joints for connection of the control line  $\frac{3}{8}$ " to the filler neck. Other screw joints are available on request.
- The control line ( $\frac{3}{8}$ " ) is to be attached on site –
- Condensation chamber for collecting steam condensation and protection of the operating diaphragm against extreme temperatures. This chamber is necessary for steam and liquids above 300 °F (150 °C).
- Extension and condensation chamber for temperatures above 430 °F (220 °C).

## Ordering text

Pressure Reducing Valve **Typ 2422/2424**

NPS (DN) ..., body material ..., Class ...

$C_V$  ( $K_{VS}$ ) coefficient ..., set point range ... psi (bar)

Optionally, accessories ..., special version ...

Specifications subject to change without notice.

