

**Application**

Control valve for process engineering applications with high industrial requirements

<b>Nominal sizes</b>	<b>DN 15 to 200</b>
<b>Nominal pressures</b>	<b>PN 16 to 400</b>
<b>Temperatures</b>	<b>-200 to 500 °C</b>

**Conversion of valve sizing coefficients:**

$$C_v \text{ (in US gallons/min)} = 1.17 \cdot K_{vs} \text{ (in m}^3\text{/h)}$$

$$K_{vs} \text{ (in m}^3\text{/h)} = 0.86 \cdot C_v \text{ (in US gallons/min)}$$



Type 3256 Angle Valve optionally operated with

- Type 3271 Pneumatic Actuator (Type 3256-1 Control Valve) or
- Type 3277 Pneumatic Actuator (Type 3256-7 Control Valve) for integral positioner attachment.

Valve body optionally made of

- High-temperature steel,
- Cold-resisting steel or
- Stainless cast steel.

Valve plug optionally with

- Metal sealing,
- Soft sealing up to PN 40 or
- Lapped-in metal sealing,
- Balanced plug to handle large differential pressures.

Stuffing boxes optionally with

- Spring-loaded, PTFE V-ring packings or
- Two adjustable high-temperature (HT) packings, optionally available with a test connection between the two packings.

The control valves, designed according to the modular assembly principle, can be equipped with various accessories:

Positioners, solenoid valves and other accessories according to DIN EN 60534-6 and NAMUR recommendation. See Information Sheet T 8350 EN for details.

**Versions**

**Standard version** (Fig. 1) · DN 15 to 150 in PN 16 to 160, DN 200 in PN 40 to 100, with PTFE packing for temperatures from -10 to 220 °C or with adjustable high-temperature packings for -10 to 350 °C.

- **Type 3256-1** (Fig. 1) · With Type 3271 Pneumatic Actuator (350 to 2800 cm<sup>2</sup>).
- **Type 3256-7** · With Type 3277 Pneumatic Actuator (350 and 700 cm<sup>2</sup>) for integral positioner attachment (see Data Sheet T 8311 EN for details).

**Additional versions with**

- **Nominal pressures > PN 160 to 400** · On request
- **Welding ends or welding neck ends** acc. to DIN EN 12 627
- **Flow divider** for noise level reduction · See T 8081 EN
- **AC-Trim** · See Data Sheets T 8082 EN, T 8083 EN
- **Heating jacket** · Details on request



Fig. 1 · Type 3256-1 Pneumatic Control Valve with Type 3271 Actuator, positioner and solenoid valve

- **Insulating section or metal bellows seal** · See Technical Data
- **Additional handwheel** · See T 8310 EN and T 8311 EN
- **Version according to US standards** · Sizes 1/2" to 8", ANSI Class 300 to 2500 · See Data Sheet T 8066 EN
- **Type 3256-3 Hand-operated Control Valve** · With Type 3273 Manual Actuator for valves with a max. travel of 30 mm · See Data Sheet T 8312 EN
- **Type 3256-2 Electric Control Valve** · On request

### Principle of operation (Figs. 2 to 4)

The process medium flows through the valve in the direction indicated by the arrow. The position of the valve plug determines the cross-sectional area of flow between the valve seat and the plug.

The version with metal bellows seal (Fig. 3) is equipped with a test connection to allow the monitoring of the stainless steel bellows.

A pressure-balanced plug (Fig. 4) needs to be used when high pressures or differential pressures act on the plug and the force produced by the actuator is insufficient.

The control valves can be equipped with St I or St III flow dividers (see Data Sheet T 8081 EN for details).

### Fail-safe action

Depending on how the compression springs are arranged in the pneumatic actuator (see Data Sheet T 8310 EN for details), the control valve offers two fail-safe actions which become effective upon a supply air failure:

**"Actuator stem extends"** (fail-close)

The valve is closed when the air supply fails.

**"Actuator stem retracts"** (fail-open)

The valve is opened when the air supply fails.

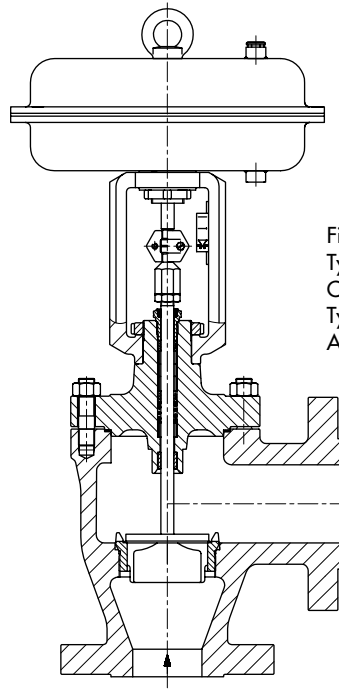

Fig. 2  
Type 3256-1 Pneumatic  
Control Valve with  
Type 3271 Pneumatic  
Actuator

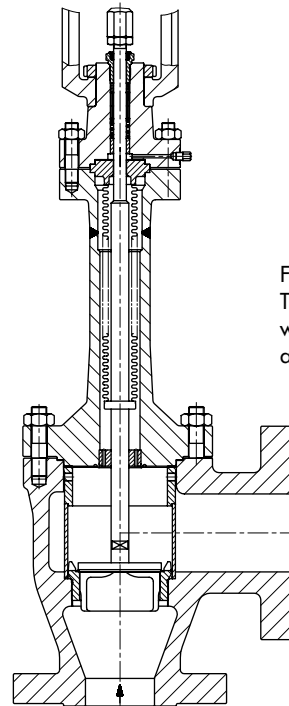

Fig. 3  
Type 3256 Angle Valve  
with metal bellows seal  
and St I flow divider

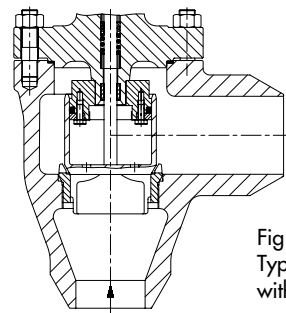

Fig. 4  
Type 3256 Angle Valve  
with balanced valve plug

**Table 1 · Technical Data for Type 3256 Angle Valve**

Material		Cast steel 1.0619	Cast steel 1.7357	Stainless cast steel 1.4581
Nominal size	DN	DN 15 ... 150 · DN 200 up to PN 100		
Nominal pressure <sup>1)</sup>	PN	PN 16 ... 160		
End connection	Flanges	All DIN EN versions		
	Welding ends	DIN EN 12627		
Seat/plug sealing		Metal sealing, soft sealing or lapped-in metal sealing		
Characteristic		Equal percentage or linear		
Rangeability		50 : 1		
<b>Temperature ranges [°C]</b> · Permissible operating pressures according to pressure-temperature diagram (see Information Sheet T 8000-2 EN)				
Valve body without insulating section		-10 ... 220 °C · with HT packing: -10 ... 350 °C		
Body with	Insulating section	-10 ... 400 °C	-10 ... 500 °C	-10 ... 450 °C
	Bellows section	-10 ... 400 °C	-10 ... 500 °C	-10 ... 450 °C
Valve plug <sup>2)</sup>	Standard	Metal sealing	-200 ... 500 °C	
		Soft sealing	-200 ... 220 °C	
	Balanced	With PTFE ring	-200 ... 220 °C	
		With graphite ring	220 ... 500 °C	
<b>Leakage class</b> according to DIN EN 1349: 2000				
Valve plug	Standard	Metal sealing	IV	
		Soft sealing	VI	
Lapped-in metal		IV-S2; DN 100 and larger: IV-S1		
Balanced	With PTFE ring	IV		
	With graphite ring	III		

<sup>1)</sup> Up to PN 400 on request<sup>2)</sup> Only when suitable body material is used**Table 2 · Materials** (material numbers according to EN)

Standard version		Cast steel 1.0619	Cast steel 1.7357	Stainless cast steel 1.4581
Valve body <sup>1)</sup>				
Seat/plug <sup>2)</sup>	Metal sealing	1.4006/1.4008		1.4571/1.4581
	Sealing ring for soft sealing	PTFE with glass fiber		
	Sealing ring for balanced plug	PTFE with carbon · Graphite		
Guide bushings		1.4112		2.4610
Stuffing box packing		V-ring packing of PTFE with carbon, spring of 1.4310 or HT packing		
Body gasket		Metal		
<b>Insulating section</b>		1.7335		1.4571
<b>Metal bellows seal</b>				
Intermediate piece		1.7335		1.4571
Metal bellows			1.4571	
Heating jacket			1.4541	

<sup>1)</sup> Also see pressure-temperature diagrams (T 8000-2 EN)  
Material for temperatures above 500 °C: 1.7380  
Material for cryogenic service: 1.6220 or 1.4308

<sup>2)</sup> All seats and valve plugs with metal sealing also available with Stellite facing or plugs of pure Stellite

**Table 3 · K<sub>vs</sub> values**

**Table 3a · Overview with St I flow divider (K<sub>vs</sub> I) or St III flow divider (K<sub>vs</sub> III)**

K <sub>vs</sub>	0.1 0.16 0.25 0.4	0.63	1.0	1.6	2.5	4	6.3	10	16	25	40	63	100	160	250	360	630
K <sub>vs</sub> I	-			1.45	2.2	3.6	5.7	9	14.5	22	36	57	90	144	225	320	560
K <sub>vs</sub> III	-					3.0	4.8	7.5	12	20	30	47	75	120	190	270	-
Seat Ø	6			12		24			31	38	50	63	80	100	125	150	200
Travel	15										30			60			

**Table 3b · Versions without flow divider** · Versions in highlighted fields also available with balanced valve plug

K <sub>vs</sub>	0.1 0.16 0.25 0.4	0.63	1.0	1.6	2.5	4	6.3	10	16	25	40	63	100	160	250	360	630
DN <sup>1)</sup>																	
15	•	•	•	•	•	•											
25	•	•	•	•	•	•	•	•									
40	•	•	•	•	•	•	•	•	•	•							
50						•	•	•	•	•	•						
80						•	•	•	•	•	•	•	•				
100										•	•	•	•	•			
150												•	•	•	•	•	
200														•	•	•	•

**Table 3c · Versions with St I flow divider** · Versions in highlighted fields also available with balanced valve plug

K <sub>vs</sub> I	-			1.45	2.2	3.6	5.7	9	14.5	22	36	57	90	144	225	320	560
DN <sup>1)</sup>																	
15				•	•	•											
25				•	•	•	•	•									
40				•	•	•	•	•	•	•							
50						•	•	•	•	•	•						
80						•	•	•	•	•	•	•	•				
100										•	•	•	•	•			
150												•	•	•	•	•	
200														•	•	•	•

**Table 3d · Versions with St III flow divider** · Versions in highlighted fields also available with balanced valve plug

K <sub>vs</sub> III	-					3.0	4.8	7.5	12	20	30	47	75	120	190	270	320
DN <sup>1)</sup>																	
50 <sup>2)</sup>						•	•	•									
80						•	•	•	•	•	•						
100										•	•	•					
150												•	•	•	•		
200														•	•	•	

<sup>1)</sup> DN 65 on request

<sup>2)</sup> DN 50 version with St III flow divider not possible with bellows seal

**Table 4a · Permissible differential pressures  $\Delta p$  for valves with unbalanced plug with metal sealing, without metal bellows seal; fail-safe action "valve CLOSED"**

Values specified in the fields highlighted in gray correspond to the standard bench range, i.e. applied at rated travel · Values specified in the other fields apply to maximally pretensioned springs · Values in parentheses apply to 50 % travel

Table 4a · Fail-safe action "valve CLOSED" (fail-close)												
Nominal bench range (bar) with actuator (cm <sup>2</sup> )	350	0.2...1.0	0.4...1.2	0.4...2.0	0.8...2.4	0.6...3.0	1.2...3.6	1.4...2.3	2.1...3.3	–	–	
	700		0.4...1.2 (0.8...1.2)		0.8...2.4 (1.6...2.4)		1.2...3.6 (2.4...3.6)	1.4...2.3 (1.85...2.3)	2.1...3.3 (2.7...3.3)	2.35...3.8 (3.05...3.8)	2.6...4.3 (3.45...4.3)	
	1400		0.5...2.5	1.0...3.0 (2.0...3.0)	1.1...2.4		1.4...2.7 (2.05...2.7)	1.3...2.8	1.7...3.2 (2.45...3.2)			
	2800	0.4...1.2 (0.8...1.2)	0.8...2.4 (1.6...2.4)	1.0...3.0 (2.0...3.0)	1.2...3.6 (2.4...3.6)	0.9...1.6	1.1...1.8 (1.25...1.6)	1.0...2.1	1.25...2.35 (1.55...2.1)	1.1...2.6	1.5...3.0 (1.85...2.6)	
	2x2800											
Required supply pressure			Final spring value + 0.2 bar									
DN	K <sub>vs</sub>	Actuator cm <sup>2</sup>	$\Delta p$ with p <sub>2</sub> = 0 bar									
15 to 40	0.1 to 1.0	350	46.1	102	102	213	158	325	380	400	–	–
	1.6 to 2.5	350	46.1	102	102	213	158	325	380	400	–	–
	4 to 10	350	8.5	22.4	22.4	50.5	36.6	78.1	92.1	141	–	–
700		–	(106)	–	(217)	–	(329)	(252)	(370)	(400)	–	
50	10	350	7.7	22	22	49.5	35.5	77.3	91.3	140	–	–
		700	–	(105)	–	(217)	–	(328)	(252)	(370)	(400)	–
40 to 80	16	350	4.1	12.4	12.4	29.1	21	45.8	54.2	83.4	–	–
		700	–	(62.5)	–	(129)	–	(196)	(150)	(221)	(250)	(284)
40 to 100	25	350	–	7.9	7.9	19	13.4	30.1	35.7	55.1	–	–
		700	–	(41.2)	–	(85.7)	–	(130)	(99.6)	(147)	(166)	(188)
50 to 100	40	700	4.3	10.7	10.7	23.6	17.1	36.4	42.8	65.3	73.3	81.3
		1400	–	(49.2)	–	(100)	–	(126)	–	(129)	–	(155)
80 to 150	63	700	–	6.3	6.3	14.4	10.4	22.5	26.5	40.7	45.7	50.8
		1400	–	(30.6)	–	(62.9)	–	(79.1)	–	(81.1)	–	(97.3)
80 to 150	100	700	–	–	–	8.7	6.2	13.7	16.3	25	28.2	31.3
		1400	–	(18.8)	–	(38.8)	–	(48.8)	–	(50.1)	–	(60.1)
100 to 150	160	700	–	–	–	5.4	–	8.7	10.3	15.9	17.9	19.9
		1400	–	(11.9)	–	(24.7)	–	(31.1)	–	(31.9)	–	(38.3)
200	160	700	–	–	–	5.4	–	8.6	10.2	15.8	17.8	19.8
		1400	–	(11.8)	–	(24.6)	–	(31)	–	(31.8)	–	(38.2)
150	250	1400	–	–	–	7.5	4.4	9.5	10.5	13.6	12.6	16.7
		2800	(15.7)	(32.1)	(40.3)	(48.5)	–	(24.9)	–	(31.1)	–	(37.2)
200	250	1400	–	–	–	7.4	4.3	9.5	10.5	13.6	12.5	16.6
		2800	(15.6)	(32)	(40.3)	(48.5)	–	(24.9)	–	(31)	–	(37.2)
		2x2800	(31.2)	(64)	(80.6)	(97)	–	(49.8)	–	(62)	–	(74.4)
150	360	1400	–	–	–	5.1	–	6.5	7.2	9.4	8.7	11.5
		2800	(10.8)	(22.2)	(27.9)	(33.6)	–	(17.2)	–	(21.5)	–	(25.8)
200	360	1400	–	–	–	5.1	–	6.5	7.2	9.3	8.6	11.5
		2800	(10.7)	(22.2)	(27.9)	(33.6)	–	(17.2)	–	(21.5)	–	(25.7)
		2x2800	(21.4)	(44.4)	(55.8)	(67.2)	–	(34.4)	–	43	–	(51.4)
200	630	1400	–	–	–	–	–	–	4	5.2	4.7	6.4
		2800	(6)	(12.4)	(15.6)	(18.8)	–	(9.6)	–	(12)	–	(14.4)
		2x2800	(12)	(24.8)	(31.2)	(37.6)	–	(19.2)	–	(24)	–	(28.8)

**Table 4b · Permissible differential pressures  $\Delta p$  for valves with unbalanced plug with metal sealing, without metal bellows seal; fail-safe action "valve OPEN"**

Table 4b · Fail-safe action "valve OPEN" (fail-open)						
Nominal bench range (bar) with actuator (cm <sup>2</sup> )		350	0.2 ... 1.0 (0.2 ... 0.6)			
		700				
		1400				
		2800				
		2x2800				
Required supply pressure		1.4	2.4	4.0	6.0	
DN	K <sub>vs</sub>	Actuator cm <sup>2</sup>	$\Delta p$ with p <sub>2</sub> = 0 bar			
15 to 40	0.1 to 1.0	350	102	380	400	–
	1.6 to 2.5	350	101	380	400	–
50	4 to 10	350	22.4	92.1	203	343
		700	(106)	(245)	(400)	–
40 to 80	16	350	21.6	91.3	203	342
		700	(105)	(244)	(400)	–
40 to 100	25	350	12.4	54.2	121	204
		700	(62.5)	(146)	(280)	(400)
50 to 100	40	350	7.9	35.7	80.1	136
		700	(41)	(97)	(185)	(297)
80 to 150	63	700	10.6	42.7	94.1	158
		1400	(49)	(113)	(216)	(344)
80 to 150	100	700	6.2	26.4	58.7	99.2
		1400	(30.4)	(71)	(135)	(216)
100 to 150	160	700	–	16.2	36.2	61.3
		1400	(18.7)	(43.7)	(84)	(134)
200	160	700	–	10.2	23	39.1
		1400	(11.8)	(27.8)	(53.5)	(85)
150	250	700	–	10.0	22.9	38.9
		1400	(11.6)	(27.7)	(53.3)	(85)
200	250	1400	–	13.6	30	50.6
		2800	(15.6)	(36.2)	(69)	(110)
		1400	–	13.5	29.9	50.4
150	360	2800	(15.5)	(36.1)	(69)	(110)
		2x2800	(–31)	(72)	(138)	(220)
		1400	–	9.4	20.8	35
200	360	2800	(10.8)	(25)	(47.8)	(76.4)
		1400	–	9.3	20.7	34.9
		2800	(10.7)	(25)	(47.8)	(76.3)
200	630	2x2800	(21.4)	(50)	(95.6)	(152)
		1400	–	5.1	11.5	19.5
		2800	(5.9)	(13.9)	(26.8)	(42.8)
		2x2800	(11.8)	(27.8)	(53.6)	(85.6)

#### Notes on differential pressure tables

The differential pressure tables were prepared under the following conditions:

- Medium flow directed against the closing direction of the valve plug
- Version with valve plug with metal sealing
- Version with PTFE stuffing box
- Tables 4a and 4b for unbalanced valve plug with downstream pressure p<sub>2</sub> = 0 bar
- For the listed maximum differential pressures and the previously mentioned conditions, the leakage rate stated in Table 1 is not exceeded
- All pressures in bar (gauge)
- The stated differential pressures can be limited by the pressure-temperature diagram

#### Note on fail-safe action "valve CLOSED":

Always use pretensioned spring ranges for actuators with reduced travels.

**Note!** Permissible differential pressures are available on request for special versions with:

- Soft sealing or
- Lapped-in metal plug,
- Metal bellows seal or
- Balanced valve plug with graphite ring.

#### Selection and sizing of the control valve

1. Calculate the appropriate K<sub>v</sub> value according to DIN EN 60534.
2. Select the nominal size and K<sub>vs</sub> value according to Table 3.
3. Determine the permissible differential pressure  $\Delta p$ . Select the appropriate actuator according to Tables 4a to 5b.
4. Select materials, pressure and temperature according to Tables 1 and 2 and the pressure-temperature diagram (see T 8000-2 EN)
5. Select accessories according to Tables 1 and 2.

**Table 5 · Permissible differential pressures  $\Delta p$  for valves with balanced plug with metal sealing and PTFE ring, without metal bellows seal**

Values specified in the fields highlighted in gray correspond to the standard bench range, i.e. applied at rated travel · Values specified in the other fields apply to maximally pretensioned springs · Values in parentheses apply to 50 % travel

Table 5a · Fail-safe action "valve CLOSED" (fail-close)									Table 5b · "Valve OPEN" (fail-open)		
Nominal bench range (bar) with actuator (cm <sup>2</sup> )	700	0.4...2.0	0.8...2.4 (1.6...2.4)	–	–	0.6...3.0	1.2...3.6	0.4 ... 2.0 (0.4 ... 1.2)	2.4	4.0	6.0
	1400			–	–	–	–				
	2800			0.5...2.5	1.0...3.0 (2.0...3.0)	0.6...3.0	1.2...3.6 (2.4...3.6)				
	2x2800										
Required supply pressure		Spring final value + 0.2 bar									
DN	K <sub>vs</sub>	Actuator cm <sup>2</sup>	$\Delta p$ with p <sub>2</sub> = 0 bar								
80 100	63	700	57.4	155	–	–	106	252	57.4	400	–
		1400	–	(400)	–	(400)	–	–	(400)	–	–
150	63	700	22.2	62.1	–	–	42.2	102	22.2	182	382
		1400	–	(302)	–	(381)	–	–	(221)	(400)	–
80 100	100	700	48.1	146	–	–	96.8	243	48.1	400	–
		1400	–	(400)	–	(400)	–	–	(400)	–	–
150	100	700	18.4	58.3	–	–	38.4	98.3	18.4	178	378
		1400	–	(298)	–	(378)	–	–	(218)	(400)	–
100	160	700	37.2	135	–	–	85.9	232	37.2	400	–
		1400	–	(400)	–	(400)	–	–	(400)	–	–
150	160	700	13.9	53.8	–	–	33.9	93.8	13.9	174	373
		1400	–	(293)	–	(373)	–	–	(213)	(400)	–
200	160	700	4.6	20.2	–	–	12.4	35.8	4.6	67	145
		1400	–	(114)	–	(145)	–	–	(82.6)	(207)	(363)
150	250	1400	48.3	128	68.2	168	–	–	48.3	368	400
		2800	–	(400)	–	(400)	–	(400)	(400)	–	–
200	250	1400	18	49.2	25.8	64.8	–	–	18	143	299
		2800	–	(236)	–	(298)	–	(361)	(174)	(400)	–
		2x2800	–	(400)	–	(400)	–	(400)	(348)	(400)	–
150	360	1400	42.6	123	62.6	162	–	–	42.7	362	400
		2800	–	(400)	–	(400)	–	(400)	(400)	–	–
200	360	1400	15.8	47	23.6	62.6	–	–	15.3	109	265
		2800	–	(234)	–	(296)	–	(359)	(172)	(400)	–
		2x2800	–	(400)	–	(400)	–	(400)	(344)	(400)	–
200	630	1400	11.4	42.6	19.2	58.2	–	–	11.4	136	292
		2800	–	(230)	–	(292)	–	(354)	(167)	(400)	–
		2x2800	–	(400)	–	(400)	–	(400)	(334)	(400)	–

**Table 6 · Dimensions in mm for Type 3256-1 and Type 3256-7 Control Valve in standard version**

Valve	DN	15	25	40	50	80	100	150	200
Length L	PN 10... 40	90	100	115	125	155	175	225	275
	PN 63...160	105	115	130	150	190	215	275	325
H1 for actuator	350 cm <sup>2</sup>	374	369	369	415	400	410	–	–
	700 cm <sup>2</sup>	374	369	369	415	400	410	628	965
	1400 cm <sup>2</sup>	–			470	455	465	628	965
	2800 cm <sup>2</sup>	–			655	640	650	713	1050

Actuator	cm <sup>2</sup>	350	700	1400	2800	2 x 2800
Diaphragm Ø D		280	390	530	770	
H <sup>1)</sup>		82	200	287	620	1130
H3 <sup>2)</sup>		110	190	610	650	
Thread		M 30 x 1.5		M 60 x 1.5	M 100 x 2	
a (with Type 3271 Actuator)		G 3/8 (3/8 NPT)		G 3/4 (3/4 NPT)	G 1 (1 NPT)	
a2 (with Type 3277 Actuator)		G 3/8 (3/8 NPT)		–		

<sup>1)</sup> Actuator 350 cm<sup>2</sup> without lifting ring

<sup>2)</sup> Minimum clearance to disassemble the actuator

**Table 7 · Weights for Type 3256-1 and Type 3256-7 Control Valve in standard version**

Valve	DN	15	25	40	50	80	100	150	200
Valve without actuator (approx. kg)	PN 16 ... 40	12	15	22	35	58	75	190	420
	PN 63 ...160	20	25	33	58	92	125	300	On request

Actuator	cm <sup>2</sup>	350	700	1400	2800	2 x 2800
Type 3271 (approx. kg) <sup>1)</sup>	Without –	8	22	70	450	950
	With handwheel	13	27	Only with side-mounted handwheel, see T 8310 EN		
Type 3277 (approx. kg) <sup>1)</sup>	Without –	12	26	–		
	With handwheel	17	31	–		

<sup>1)</sup> Top row without handwheel, bottom row with handwheel

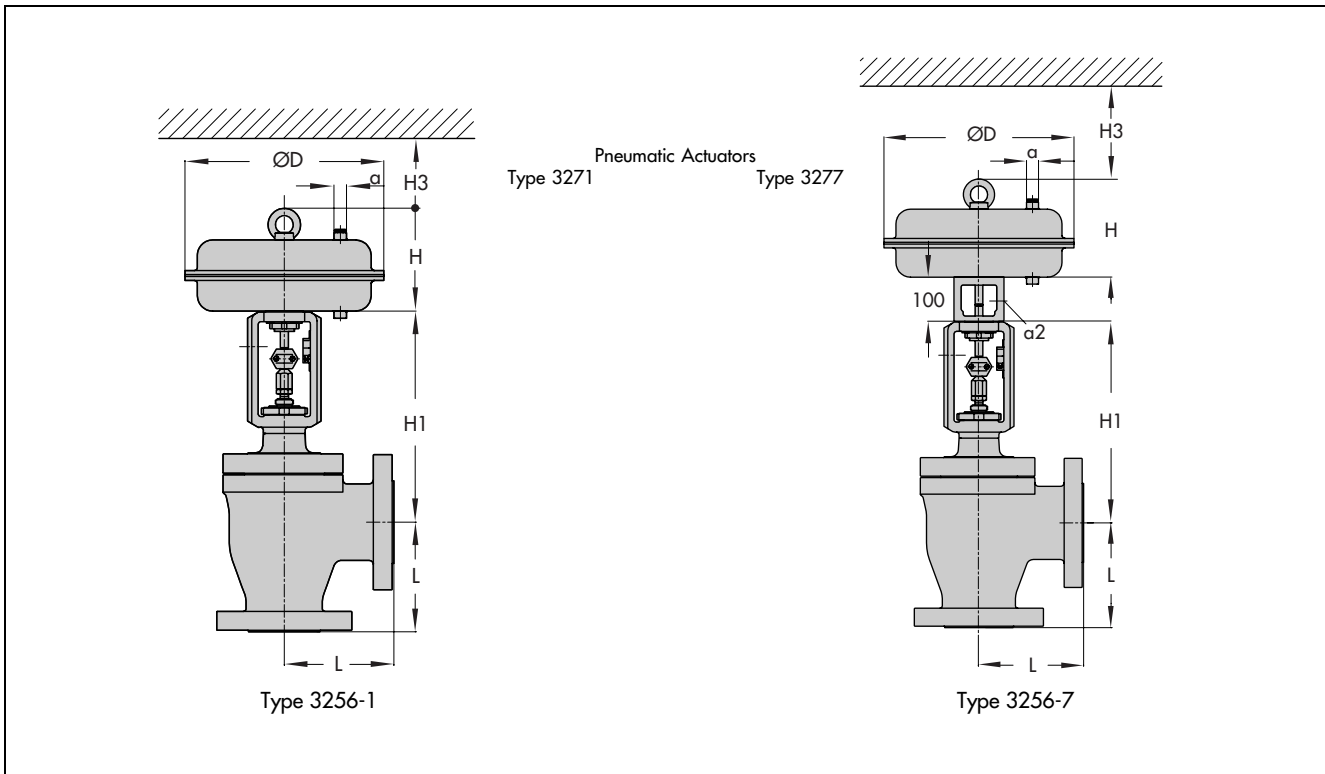

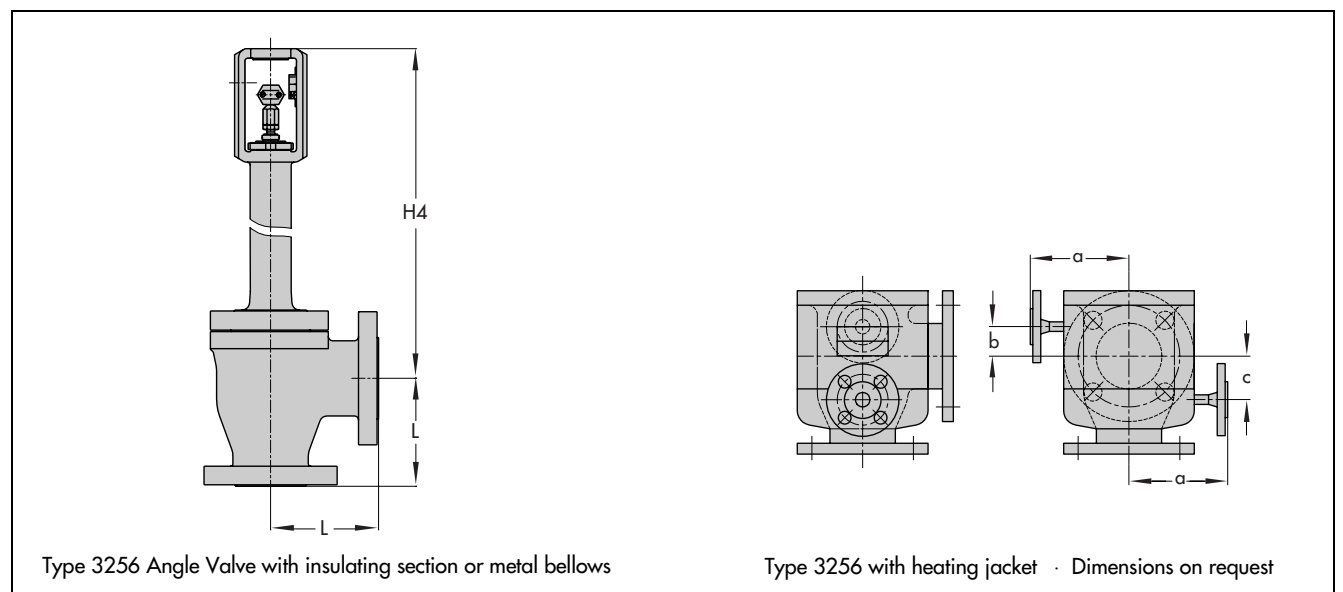

**Table 8 · Dimensions and weights for Type 3256 Angle Valve in standard version with insulating section · Without actuator**

Nominal size	DN	15	25	40	50	80	100	150	200
Height H4 for actuator	350 cm <sup>2</sup>	575	570	571	685	670	680	–	–
	700 cm <sup>2</sup>	575	570	571	685	670	680	978	–
	1400 cm <sup>2</sup>	–			740	725	735	978	2015
	2800 cm <sup>2</sup>	–			925	910	920	1063	2100
Weight (kg) without actuator	PN 16 ... 40	18	21	28	45	68	85	200	On request
	PN 63 ...160	26	31	39	68	102	135	315	

**Table 9 · Dimensions and weights for Type 3256 Angle Valve in standard version with metal bellows · Without actuator**

Nominal size	DN	15	25	40	50	80	100	150	200
H4 for PN 16 ... 40 for actuator	350 cm <sup>2</sup>	572	567	568	794	779	769	–	–
	700 cm <sup>2</sup>	572	567	568	794	779	769	991	–
	1400 cm <sup>2</sup>	–			849	834	824	1036	2015
	2800 cm <sup>2</sup>	–			1034	1019	1009	1121	2100
H4 for PN 63 ... 160 for actuator	350 cm <sup>2</sup>	572	567	568	794	779	769	–	–
	700 cm <sup>2</sup>	572	567	568	794	779	769	991	–
	1400 cm <sup>2</sup>	–			849	834	824	1168	On request
	2800 cm <sup>2</sup>	–			1034	1019	1009	1253	
Weight (kg) without actuator	PN 16 ... 40	18	21	28	45	68	85	200	On request
	PN 63 ...160	26	31	39	68	102	135	315	



**The following details are required on ordering**

Nominal size	DN	Process medium	Density in kg/m <sup>3</sup> and temperature in °C
Nominal pressure	PN	Flow rate	kg/h or m <sup>3</sup> /h
Body material	According to Table 2	Pressure	under standard or operating conditions
End connection	Flanges/welding ends	Accessories	p <sub>1</sub> and p <sub>2</sub> in bar (absolute pressure p <sub>abs</sub> )
Valve plug	Standard/balanced		with minimum, standard and maximum flow rate
	Soft sealing, metal sealing or lapped-in metal sealing		Positioner and/or limit switches
Characteristic	Equal percentage or linear		
Actuator	Type 3271 or Type 3277 (see T 8310 EN or T 8311 EN)		
Fail-safe action	Valve CLOSED/valve OPEN		Specifications subject to change without notice.



SAMSON AG · MESS- UND REGELTECHNIK  
Weismüllerstraße 3 · 60314 Frankfurt am Main · Germany  
Phone: +49 69 4009-0 · Fax: +49 69 4009-1507  
Internet: <http://www.samson.de>

**T 8065 EN**