

## Pneumatic Control Valve Type 3253-1 and Type 3253-7 Three-way Valve Type 3253

### Application

Diverting or mixing valves for heavy-duty service in process engineering

**Nominal sizes** DN 15 to 400  
**Nominal pressure** PN 10 to 160  
**Temperatures** –200 to +500 °C

Type 3253 Three-way Valve optionally operated with

- Type 3271 Pneumatic Actuator (Type 3253-1 Control Valve) or
- Type 3277 Pneumatic Actuator (Type 3253-7 Control Valve) for integral positioner attachment

Valve body optionally made of

- Cast iron (DN 200 or larger for PN 10; DN 150 for PN 16)
- Cast steel (DN 15 to 100 for PN 63 or greater; DN 150 to 400 for PN 16 or greater) or
- Cast stainless steel

Stuffing box containing either two spring-loaded PTFE V-ring packings or two adjustable high-temperature (HT) packings.

Optional test connection between the two packings

Conversion between mixing and diverting services by **reversing** the seat-guided valve plug

The control valves, designed according to the modular assembly principle, can be equipped with various accessories:

Positioners, limit switches, solenoid valves and other equipment according to IEC 60534-6 and NAMUR recommendation (see Information Sheet T 8350 EN for details).

### Versions

**Standard version** with PTFE packing for temperatures from –10 to +220 °C or with adjustable high-temperature packings for –10 to +350 °C

**Type 3253-1** (Fig. 1) · Type 3253 Valve and Type 3271 Actuator with 350 to 2800 cm<sup>2</sup> – see Data Sheet T 8310-1/-2 EN for details

**Type 3253-7** · Type 3253 Valve and Type 3277 Actuator with 350 or 700 cm<sup>2</sup> – see Data Sheet T 8310-1 EN for details

### Additional versions with

- **Nominal pressures >PN 160 to 400** · On request
- **Insulating section or bellows seal** · See Technical Data
- **Additional handwheel** · See T 8310-1/-2 EN
- **Version according to US standards** · Nominal sizes NPS ½ to 16, ANSI Class 300 to 2500 on request
- **Type 3244** · In DN 15 to 150, PN 10 to 40; NPS ½ to 6, ANSI Class 150 to 300 (see Data Sheet T 8026 EN).
- **Type 3253-2 Electric Control Valve** · On request

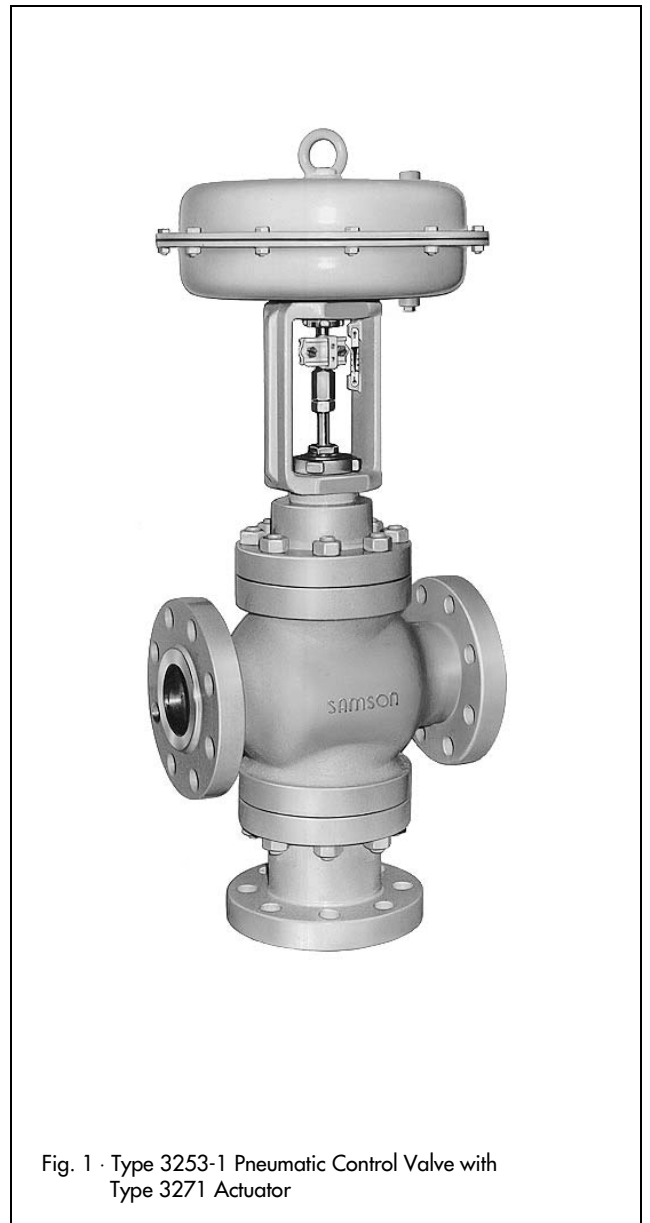

Fig. 1 · Type 3253-1 Pneumatic Control Valve with Type 3271 Actuator

- **Type 3253-3 Hand-operated Valve** · With Type 3273 Hand-operated Actuator (see T 8312 EN for details)

### Principle of operation

Depending on plug arrangement, the three-way valve can be used for mixing or diverting service.

When used as a mixing valve, the process media to be mixed enter through valve ports A and B. The combined stream leaves at port AB (Fig. 2 and 3). The flow rate from valve ports A and B to port AB depends on the cross-sectional area of flow between the seats and the valve plugs.

When used as a diverting valve, the process medium enters at port AB and the partial streams leave at valve ports A and B (Fig. 4).

### Fail-safe action

Depending on how the compression springs are arranged in the pneumatic actuator (see Data Sheets T 8310-1/-2 EN for further details), the control valve offers two different fail-safe actions which become effective upon a supply air failure:

#### Actuator stem extends:

Whenever the air supply fails, either valve port B (mixing valve) or valve port A (diverting valve) is closed.

#### Actuator stem retracts:

Whenever the air supply fails, either valve port A (mixing valve) or valve port B (diverting valve) is closed.

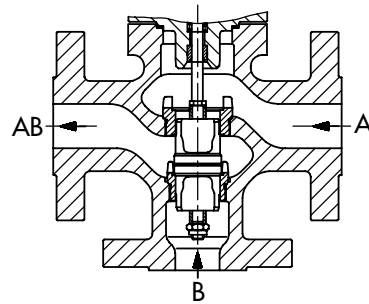

Fig. 3 · Type 3253 Three-way Valve  
Body version for DN 15 to 40,  
Plug arrangement for mixing service,  
Plug arrangement for diverting service DN 15 to 25

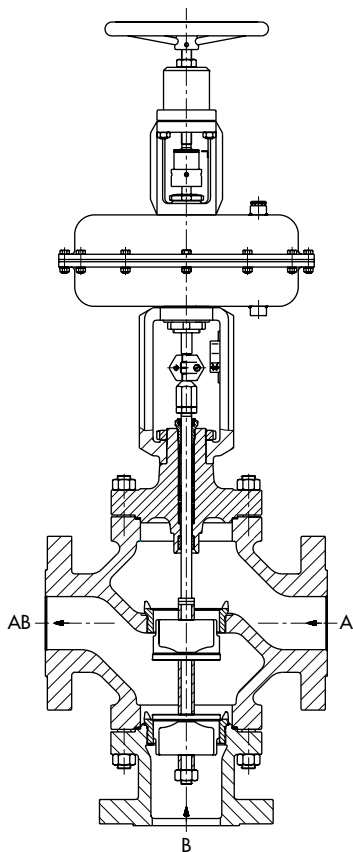

Fig. 2 · Type 3253-1 Control Valve with Type 3271  
Pneumatic Actuator and additional handwheel,  
Body version for DN 50 to 400,  
Plug arrangement for mixing service

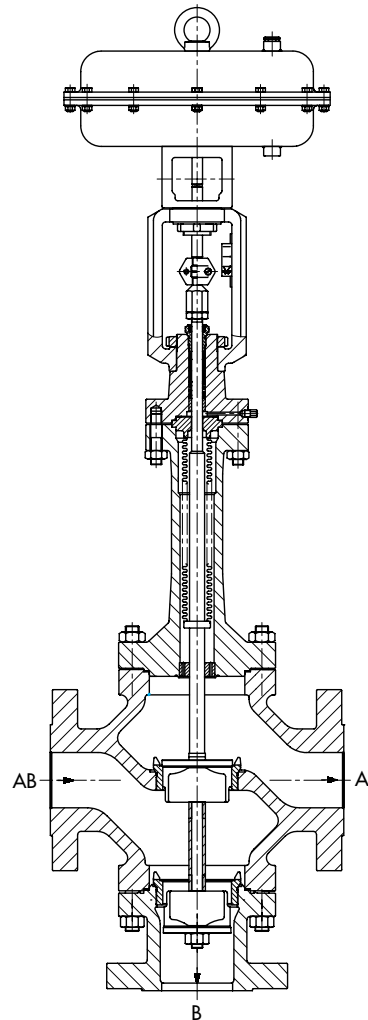

Fig. 4 · Type 3253-7 Control Valve with Type 3277  
Pneumatic Actuator (only up to DN 100),  
Body version for DN 40 to 400,  
Plug arrangement for diverting service

**Table 1 · Technical Data for Type 3253 Three-way Valve**

Material		Cast iron EN-JL1040		Cast steel 1.0619		Cast stainless steel 1.4581	
Nominal sizes	DN	15 ... 150	200 ... 400	15 ... 100	150 ... 400	15 ... 100	150 ... 400
Nominal pressure <sup>1)</sup>	PN	16	10	63 ... 160	16 ... 160	63 ... 160	16 ... 100
End connection	Flanges	All DIN EN versions · Other connections on request					
Seat/plug sealing		Metal sealing					
Characteristic		Linear					
Rangeability		50 : 1					
<b>Temperature ranges in °C</b> · Permissible operating pressures according to pressure-temperature diagram (see Information Sheet T 8000-2 EN)							
Body without insulating section		-10 ... 220 °C · up to 350 °C with HT packing					
Body with	Insul. sect.	-10 ... 300		-10 ... 400 <sup>2)</sup>		-10 ... 450	
	Bellows	-10 ... 300		-10 ... 400 <sup>2)</sup>		-10 ... 450	
Valve plug	Metal sealing	-200 ... 450					
<b>Leakage rate</b> Acc. to DIN EN 1349: 2000		I					

<sup>1)</sup> Up to PN 400 on request

<sup>2)</sup> In connection with suitable body material; for temperatures exceeding 500 °C: 1.7380

**Table 2 · Materials** (material numbers according to EN)

Standard version Valve body and bonnet		Cast iron EN-JL1040		Cast steel 1.0619		Cast stainless steel 1.4581	
Seat and plug <sup>1)</sup>		1.4006				1.4571	
Guide bushings		1.4112				2.4610	
Stuffing box packing		V-ring packing PTFE with carbon, spring 1.4310 or HT packing					
Body gaskets		Metal					
<b>Insulating section</b>		1.0460		1.7335		1.4571	
<b>Metal bellows seal</b>							
Intermediate piece		1.0460		1.7335		1.4571	
Metal bellows		1.4571					

<sup>1)</sup> All seats and plugs also available with Stellite facing

**Table 3 · Available K<sub>Vs</sub> coefficients**

K <sub>Vs</sub>	4	10	25	40	100	160	360	630	800	1500	2500
Seat Ø	24		38	50	80	100	150	200	250	300	400
Travel	15			30			60			120	
DN											
15	•										
25		•									
40			•								
50				•							
80					•						
100						•					
150							•				
200								•			
250									•		
300										•	
400											•

**Table 4a · Permissible differential pressures  $\Delta p$  for valves with and without metal bellows seal**  
**Fail-safe action "Actuator stem extends" · Pressures in bar**

Values specified in the columns highlighted in gray correspond to the standard bench range, i.e. applied at rated travel · Values specified in the other columns apply to maximum pretensioned springs.

Bench range (bar) for actuator area (cm <sup>2</sup> )		350	0.2 ... 1.0 (0.8 ... 1.2)	0.4 ... 2.0 (1.6 ... 2.4)	1.4 ... 2.3 (1.85 ... 2.3)	2.1 ... 3.3 (2.7 ... 3.3)	–	–
		700			0.5 ... 2.5 (2 ... 3)	1.1 ... 2.4 (2.05 ... 2.7)	1.3 ... 2.8 (2.45 ... 3.2)	
		1400						
		2800	–			0.9 ... 1.6 (1.4 ... 1.7)	1.0 ... 2.1 (1.8 ... 2.3)	1.1 ... 2.6 (2.2 ... 3.0)
		2 x 2800						
Required supply pressure		Lower spring range value + upper spring range value						
DN	K <sub>Vs</sub>	Actuator cm <sup>2</sup>	$\Delta p$ in bar					
15	4	350	8.5	22.5	92	141	–	–
		700	(106)	(217)	(252)	(370)	–	–
25	10	350	8.5	22.5	92	140	–	–
		700	(106)	(217)	(252)	(370)	–	–
40	25	350	–	8.2	36	55	–	–
		700	(41.5)	(86)	(100)	(147)	–	–
50	40	700	4.2	10.6	42.7	65	–	–
		1400	(49)	(100)	(126)	(129)	(155)	–
80	100	700	–	–	16.4	25	–	–
		1400	(18.8)	(38.9)	(49)	(50.2)	(60.2)	–
100	160	700	–	–	10.3	15.9	–	–
		1400	(11.2)	(24.7)	(31.2)	(32)	(38.4)	–
150	360	1400	–	10.8	13.6	14	16.8	–
		2800	–	(22.2)	(27.9)	(19.3)	(25)	(30.7)
200	630	1400	–	–	–	4	4.7	–
		2800	–	(12.4)	(15.5)	(10.7)	(13.9)	(17.2)
		2x2800	(16.6)	(25)	(31)	(21.4)	(27.8)	(34.4)
250	800	2800	–	–	–	(6.8)	(8.8)	(10.9)
		2x2800	–	–	–	(13.6)	(17.6)	(21.8)
300	1500	2800	–	–	–	–	–	3.6
		2x2800	–	–	–	–	–	7.2
400	2500	2800	–	–	–	–	–	–
		2x2800	–	–	–	–	–	4

**Table 4b · Permissible differential pressure  $\Delta p$  for valves with or without metal bellows seal  
Fail-safe action "actuator stem retracts" · Pressures in bar**

Values specified in the columns highlighted in gray correspond to the standard bench range, i.e. applied at rated travel · Values specified in the other columns apply to maximum pretensioned springs.

Bench range (bar) for actuator area (cm <sup>2</sup> )			350	0.2 ... 1.0 (0.2 ... 0.6)	0.4 ... 2.0 (0.4 ... 1.2)	1.4 ... 2.3 (1.4 ... 1.85)	2.1 ... 3.3 (2.1 ... 2.7)	–	–
			700			0.5 ... 2.5 (0.5 ... 1.5)	1.1 ... 2.4 (1.1 ... 1.75)	1.3 ... 2.8 (1.3 ... 2.05)	–
Required supply pressure			1400	–	–	–	–	–	–
			2800						
2 x 2800			Lower spring range value + upper spring range value						
DN	K <sub>vs</sub>	Actuator cm <sup>2</sup>	$\Delta p$ in bar						
15	4	350	8.5	22.5	92	141	–	–	
		700	(22.5)	(50)	(189)	(287)	–	–	
25	10	350	8.5	22.5	92	141	–	–	
		700	(22.5)	(50)	(189)	(287)	–	–	
40	25	350	–	8.2	36	55.4	–	–	
		700	(8.2)	(19.4)	(75)	(114)	–	–	
50	40	700	4.2	10.6	42.7	65	–	–	
		1400	(10.5)	(23.5)	(30)	(68.4)	(17)	–	
80	100	700	–	–	16.3	25	–	–	
		1400	(4)	(8.8)	(11.3)	(26.4)	(31.4)	–	
100	160	700	–	–	10.3	7.9	–	–	
		1400	–	(5.5)	(7.1)	(16.7)	(19.9)	–	
150	360	1400	–	–	–	7.2	8.6	–	
		2800	–	(5.1)	(6.5)	(12.2)	(13.6)	(15)	
200	630	1400	–	–	–	4	4.7	–	
		2800	–	–	–	(6.7)	(7.5)	(8.3)	
		2x2800	–	(5.4)	(7)	(13.4)	(15)	(16.6)	
250	800	2800	–	–	–	(4.2)	(4.8)	(5.3)	
		2x2800	–	–	(4.4)	(8.4)	(9.6)	(10.6)	
300	1500	2800	–	–	–	–	–	–	
		2x2800	–	–	–	5.8	6.6	7.2	
400	2500	2800	–	–	–	–	–	–	
		2x2800	–	–	–	–	–	4	

**Table 5 · Dimensions in mm for Type 3253-1 and Type 3253-7 Pneumatic Control Valve in standard version**

Valve	DN	15	25	40	50	80	100	150	200	250	300	400
Length L	PN 10 ... 40	-						480	600	730	850	1100
	PN 63 ...160	210	230	260	300	380	430	550	650	775	900	1150
H1 for actuator	350 cm <sup>2</sup>	392	392	404	457	462	482	-				
	700 cm <sup>2</sup>	392	392	404	457	462	482	732	805	860	1035	1035
	1400 cm <sup>2</sup>	-			512	517	537	732	805	860	1035	1035
	2800 cm <sup>2</sup>	-			697	702	722	817	890	1094	1290	1290
H2 approx.	PN 10 ... 40	-						480	520	595	740	830
	PN 63 ...160	115	115	130	275	275	370	535	590	730	-	-

Actuator	cm <sup>2</sup>	350	700	1400	2800	2 x 2800
Diaphragm Ø D		280	390	530	770	
H 1) <sup>1)</sup>		82	200	287	620	1134
H3 2) <sup>2)</sup>		110	190	610	650	
Thread		M 30 x 1.5		M 60 x 1.5	M 100 x 2	
α (with Type 3271 Actuator)		G 3/8 (3/8 NPT)		G 3/4 (3/4 NPT)	G 1 (1 NPT)	
α2 (with Type 3277 Actuator)		G 3/8 (3/8 NPT)		-		

1) Actuator 350 cm<sup>2</sup> without lifting ring

2) Minimum clearance required to disassemble the actuator

**Table 6 · Weights for Type 3253-1 and Type 3253-7 Pneumatic Control Valve in standard version**

Valve	DN	15	25	40	50	80	100	150	200	250	300	400
Valve without actuator (approx. kg)	PN 10 ... 40	1)							395	645	1550	2000
	PN 63 ...160	32	37	50	93	129	165	365	1)			

Actuator	cm <sup>2</sup>	350	700	1400	2800	2 x 2800
Type 3271 (approx.) <sup>2)</sup>	Without	8	22	70	450	950
	With handwheel	13	27	Only with side-mounted handwheel, see T 8310-2 EN		
Type 3277 (approx.) <sup>2)</sup>	Without	12	26	-		
	With handwheel	17	31			

1) Weights on request

2) Top row without handwheel, bottom row with handwheel

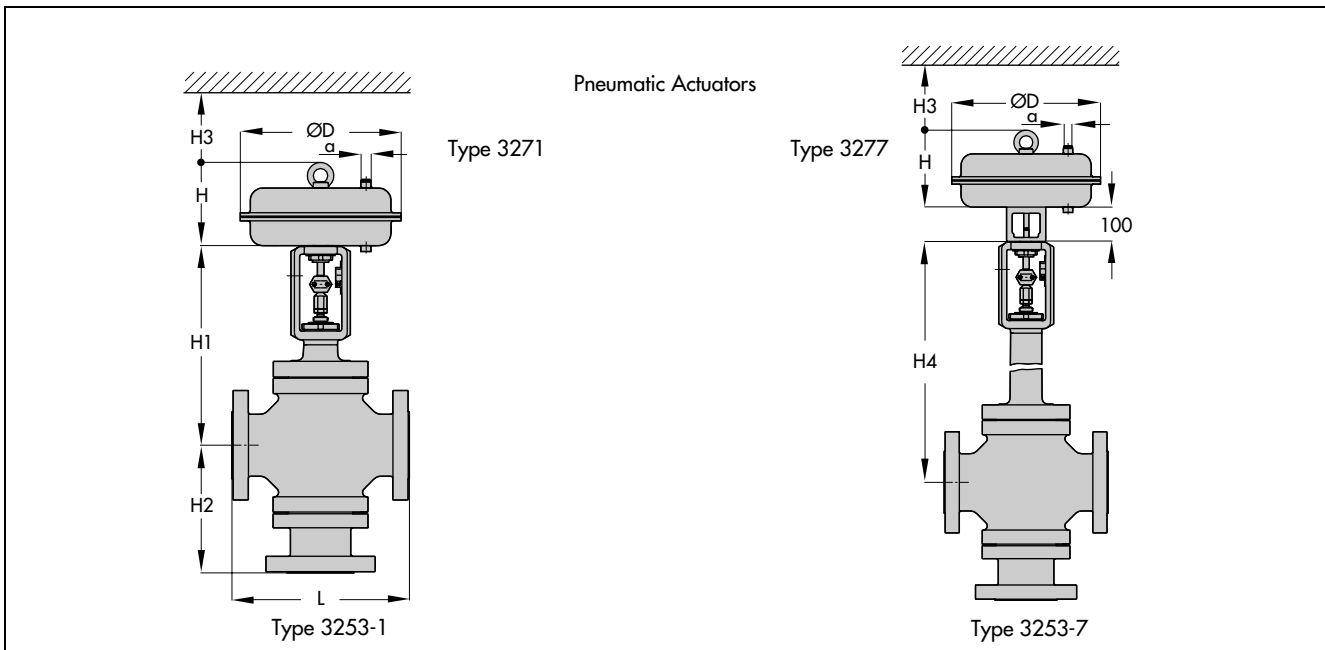

**Table 7 · Dimensions in mm and weights for Type 3253 Valve in standard version with insulating section · Without actuator**

Nominal sizes	DN	15	25	40	50	80	100	150	200	250	300	400
Height H4 for actuator	350	593	593	605	727	732	752	-				
	700	593	593	605	727	732	752	1083	1365	1485	1555	1615
	1400	-			782	787	807	1083	1365	1485	1555	1615
	2800	-			967	972	992	1168	1450	1719	1810	1870
Weight without actuator (approx. kg)	PN 16 ... 40	1)						1)				
	PN 63 ...160	37	42	55	103	139	175	380	1)			

**Table 8 · Dimensions in mm and weights for Type 3253 Valve in standard version with bellows seal · Without actuator**

Nominal sizes	DN	15	25	40	50	80	100	150	200	250	300	400
H4 for PN 16 ... 40 for actuator	350	590	590	602	836	841	841	-				
	700	590	590	602	836	841	841	1139	1455	1905	1895	1925
	1400	-			891	896	896	1139	1455	1905	1895	1925
	2800	-			1076	1081	1081	1224	1540	2139	2150	2180
H4 for PN 63 ... 160 for actuator	350	590	590	602	836	841	841	-				
	700	590	590	602	836	841	841	1271	1855	1)		
	1400	-			891	896	896	1271	1855	1)		
	2800	-			1076	1081	1081	1356	1940	1)		
Weight without actuator (apprx. kg)	PN 16 ... 40	1)						370	1)			
	PN 63 ...160	37	42	55	103	139	175	1)				

1) Data on request

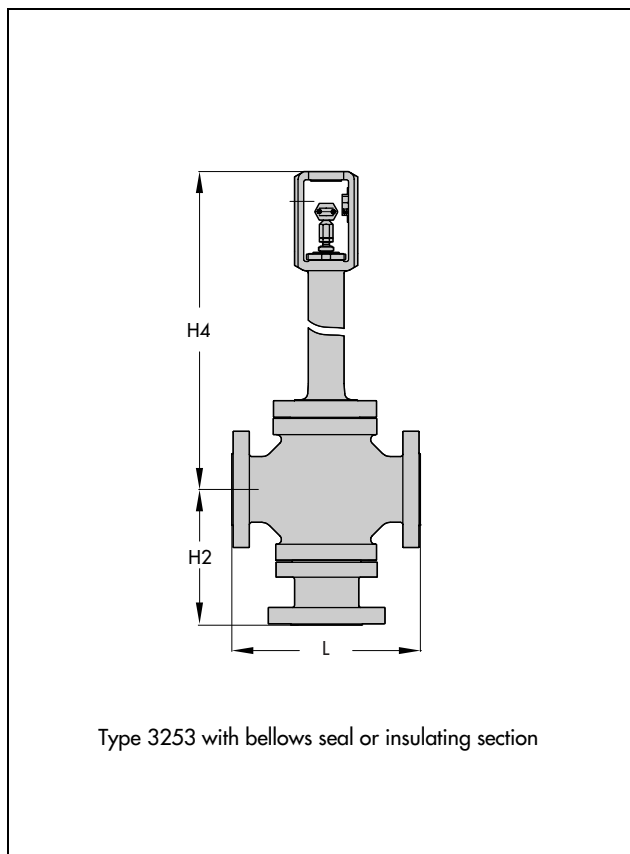

#### Selection and sizing of the control valve

1. Calculate the appropriate  $K_v$  value acc. to DIN EN 60 534
2. Select the nominal size DN and  $K_{vs}$  value according to Tables 3 and 4
3. Determine the permissible differential pressure  $\Delta p$  according to Table 4
4. Select the body material according to Tables 1 and 2 and the pressure-temperature diagram in Information Sheet T 8000-2 EN
5. Select accessories according to Tables 1 and 2

#### The following details are required on ordering

Nominal size	DN
Nominal pressure	PN
Body material	According to Table 2
End connection	Flanges
Actuator	Type 3271 or Type 3277 (see T 8310-1 EN or T 8310-2 EN)
Fail-safe action	Actuator stem extends/retracts
Process medium	Density in $\text{kg}/\text{m}^3$ and temperature in $^{\circ}\text{C}$
Flow rate	$\text{kg}/\text{h}$ or $\text{m}^3/\text{h}$ in standard or operating state
Pressure	$p_1$ und $p_2$ in bar (absolute pressure $p_{abs}$ ) both with minimum, normal and maximum flow rate
Accessories	Positioner and/or limit switches

Specifications subject to change without notice.



SAMSON AG · MESS- UND REGELTECHNIK  
Weismüllerstraße 3 · 60314 Frankfurt am Main · Germany  
Phone: +49 69 4009-0 · Fax: +49 69 4009-1507  
Internet: <http://www.samson.de>

**T 8055 EN**

2007-07