

Series 240

Types 3241-1 PSA, -7 PSA, -9 PSA Pneumatic Control Valves Type 3241 PSA Globe Valve



Application

Control valves for PSA plants (Pressure Swing Adsorption)

Valve sizes DN 15 to 150

Nominal pressure PN 10 to 40

Temperatures -10 to +220 °C

Type 3241 Globe Valve operated with

- Type 3271 Pneumatic Actuator (Type 3241-1 Control Valve)
- Type 3277 Pneumatic Actuator (Type 3241-7 Control Valve) for integral positioner attachment
- Type 3275 Pneumatic Piston Actuator (Type 3241-9 Control Valve)

Valve body made of

- Cast steel
- Cast stainless steel or cast cold-resisting steel
- Forged steel
- Forged stainless steel

Undivided valve bonnet

Valve plug

- Soft seal
- High-performance metal seal

The control valves, designed according to the modular assembly principle, can be equipped with various accessories:

Positioners, solenoid valves and other accessories according to IEC 60534-6-1 and NAMUR recommendation. Refer to Information Sheet ▶ T 8350 EN for more details.

Versions

Standard version for temperatures ranging from -10 to +220 °C

- **Type 3241-1 PSA** (Fig. 1) · DN 15 to 80 with Type 3271 Actuator (see Data Sheet ▶ T 8310-1 EN)
- **Type 3241-7 PSA** (Fig. 2) · DN 15 to 80 with Type 3277 Actuator (see Data Sheet ▶ T 8310-1 EN)
- **Type 3241-9 PSA** (Fig. 3) · DN 15 to 150, with Type 3275 Piston Actuator (▶ T 8314 EN) for integral attachment of a positioner and/or limit switch

Further versions

- **Flow divider** · For cast valves for noise reduction in both directions of flow
- **ANSI version** · See Data Sheet ▶ T 8012-1 EN
- **Versions with dimensions according to Japanese Industry Standard (JIS)** · Details on request

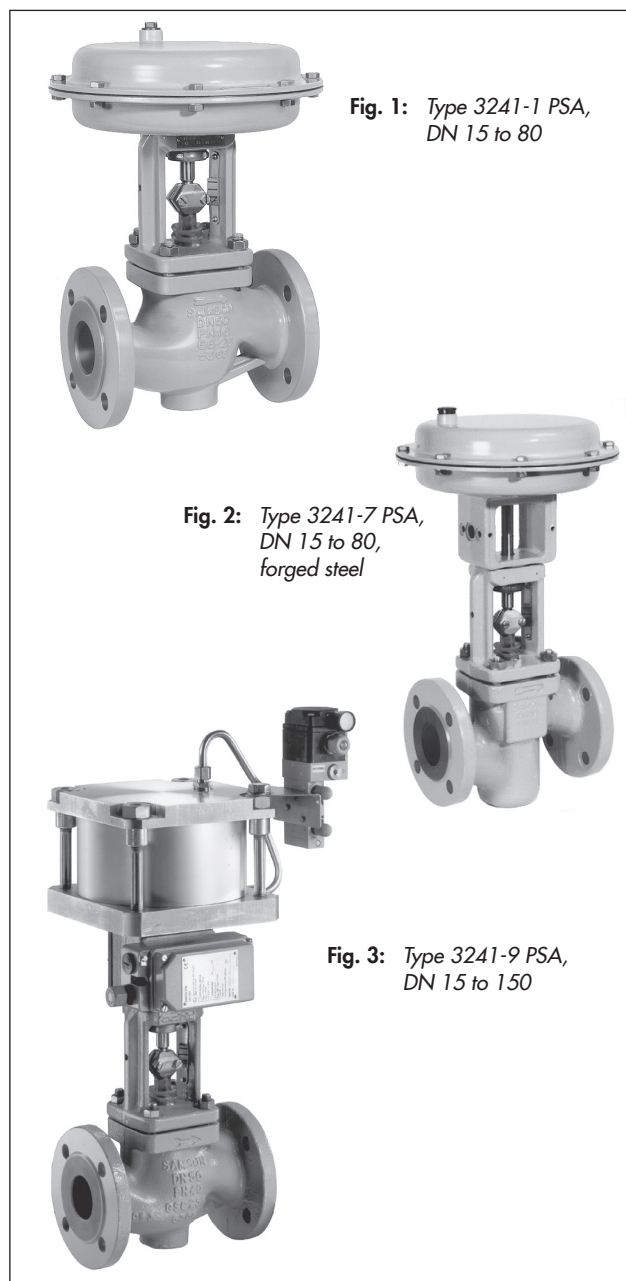

Principle of operation

The process medium flows through the valve in both directions. The valve plug position determines the cross-sectional area between the seat and plug.

Fail-safe position

Depending on how the springs are arranged in the Type 3271 or Type 3277 Actuator (► T 8310-1 EN), the valve has two different fail-safe positions effective upon air supply failure:

Actuator stem extends (fail-close)

The valve closes when the supply air fails.

Actuator stem retracts (fail-open)

The valve opens when the supply air fails.

The double-acting Type 3275 Piston Actuator does not have a fail-safe action (see ► T 8314 EN).

Notes on the differential pressure tables

The differential pressure tables have been prepared under the following conditions:

- The maximum permissible supply pressure is 4 bar for valves in sizes DN 15 to 50 and actuators with an effective diaphragm area of 700 cm²
- Process medium in flow-to-open direction
- Version with PTFE packing
- The leakage rates specified in Table 1 are not exceeded with the maximum differential pressures specified.
- The specified differential pressure may be restricted by the pressure-temperature diagram.

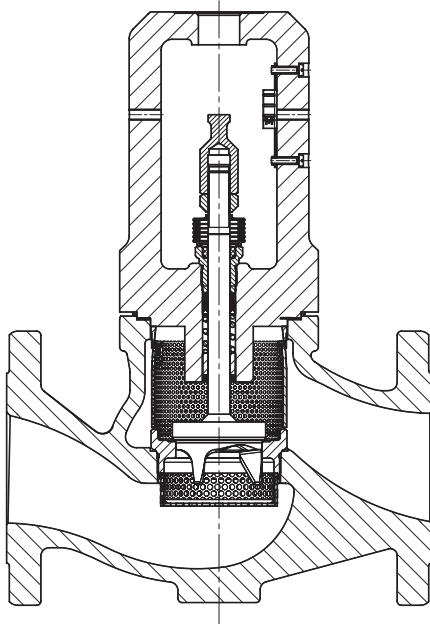

Fig. 4: Type 3241 PSA Valve, DN 15 to 150, with flow divider
St I PSA

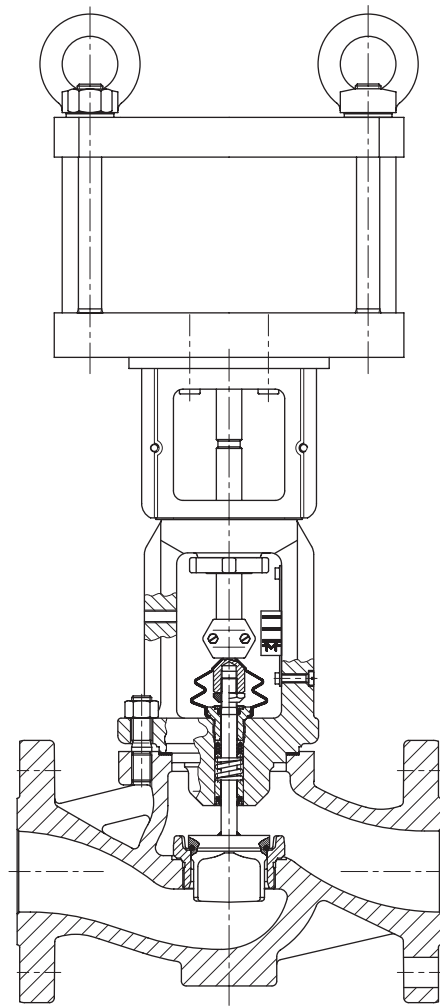

Fig. 5: Type 3241-9 PSA Control Valve, DN 15 to 150, with
Type 3275 Pneumatic Piston Actuator

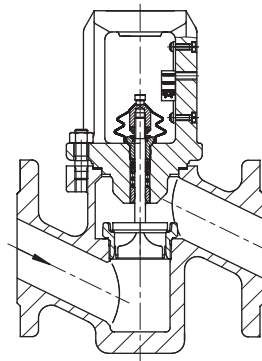

Fig. 6: Type 3241-1 PSA Valve in forged steel, DN 15 to 80

Table 1: Technical data for Type 3241 PSA Valve

Nominal size	DN	15 to 150		15, 25, 40, 50, 80	
Material		Cast steel GP240GH 1.0619	Cast stainless steel 1.4408	Forged steel P250GH 1.0460	Forged stainless steel 1.4571
Type of end connections		Flange (all DIN versions)			
Nominal pressure PN		10, 16, 25, 40			
Seat/plug seal		Soft seal or high-performance metal seal			
Characteristic		Equal percentage or linear			
Rangeability		50:1 for DN 15 to 50 · 30:1 for DN 65 and larger			
Temperature ranges in °C · Permissible operating pressures acc. to pressure-temperature diagram (see Information Sheet ► T 8000-2 EN)					
Valve		-10 to +220 °C			
Leakage class according to IEC 60534-4					
Valve plug	Soft seal	VI			
	High-performance metal seal	V			

Table 2: Materials

Standard version				
Nominal pressure	PN 16 to 40			
Valve body ¹⁾	Cast steel GP240GH 1.0619	Cast stainless steel 1.4408	Forged steel P250GH 1.0460	Forged stainless steel 1.4571
Valve bonnet	1.0460	1.4404/1.4401	1.0460	1.4571
Seat and plug	1.4006	1.4004	1.4406	1.4404
	Seal ring for soft-seated plug: PTFE with glass fiber			
Guide bushings	1.4104	1.4404	1.4104	1.4404
Packing	V-ring packing: PTFE with carbon · Spring: 1.4310 · Stem protective ring			
Body gasket	Graphite on metal core			

¹⁾ Special materials on request

Table 3: K_{VS} coefficientsTerms for control valve sizing according to IEC 60534, Parts 2-1 and 2-2: $F_L = 0.95$, $X_T = 0.75$ **Table 3.1:** Overview with flow divider St I PSA ($K_{VS I}$)

K_{VS}	1.6	2.5	4.0	6.3	10	16	25	40	60	80	63	100	160	200	260	
$K_{VS I}$	1.3	2	3.2	5	8	13	20	32	48	63	50	80	125	160	210	
Seat \varnothing mm	12			24			31	38	48	63	80	63	80	100	110	130
Travel mm	15										30					

Table 3.2: Versions without flow divider

K_{VS}	1.6	2.5	4.0	6.3	10	16	25	40	60	80	63	100	160	200	260	
Nominal size DN																
15	•	•	•													
20		•	•	•												
25			•	•	•											
32				•	•	•										
40					•	•	•									
50						•	•	•								
65							•	•	•							
80								•	•	•						
100											•	•	•			
125												•	•	•		
150												•	•			•

Table 3.3: Versions with flow divider St I PSA ($K_{VS I}$) · Versions with cast bodies only

$K_{VS I}$	1.3	2	3.2	5	8	13	20	32	48	63	50	80	125	160	210	
Nominal size DN																
15	•	•	•													
20	•	•	•													
25	•	•	•													
32				•	•	•										
40					•	•	•									
50						•	•	•								
65							•	•	•							
80								•	•	•						
100										•	•	•				
125												•		•		
150												•	•			•

Table 4: Differential pressure tables for Type 3271 and Type 3277 Actuators with Type 3241 PSA Valve · All pressures in bar

- Permissible differential pressures Δp for unbalanced plug with high-performance metal seal when $p_2 = 0$
- Values specified in the gray-shaded columns correspond to the standard application cases, i.e. operation with rated travel
- Differential pressures specified in the white columns apply to maximum pretensioned springs
- Values in parentheses are valid for 50 % travel.

Table 4.1: Fail-close valve · Valve closed with 0 bar signal pressure

Bench range with actuator		240 cm ²	0.2 to 1.0	0.3 to 1.1	0.4 to 2.0	0.6 to 2.2	0.6 to 3.0	0.9 to 3.3	–	–
		120 cm ² 350 cm ² 700 cm ²		0.4 to 1.2		0.8 to 2.4		1.2 to 3.6	1.4 to 2.3	2.1 to 3.3
		700 cm ²		(1.2 to 2.0)		(1.8 to 3.0)		(1.85 to 2.3)	(2.7 to 3.3)	
Required supply pressure			1.2	1.4	2.2	2.6	3.2	3.8	2.5	3.5
Nominal size DN	K _{Vs}	Actuator cm ²	Δp when $p_2 = 0$ bar							
15 to 25	1.6	120	–	–	28	–	–	–	40	–
	2.5	240	28	40	40	40	40	40	–	–
	4.0	350	40	40	40	40	–	–	40	–
20 to 40	6.3 10.0	120	–	–	–	–	–	–	30	40
		240	–	–	14.8	24	24	39	–	–
		350	–	–	24	38	38	40	40	40
		700	–	–	(40)	–	–	–	–	–
32 to 50	16	240	–	–	–	14	14	23	–	–
		350	–	–	13.5	30	22	47	40	40
		700	–	–	(40)	–	(40)	–	–	–
40 to 65	25	350	–	–	–	20	14	31	37	40
		700	–	–	(40)	–	(40)	–	–	–
50 to 80	40	350	–	–	–	12	8.5	19	23	35
		700	–	–	(40)	–	(40)	–	–	–
65 80	60	350	–	–	–	–	4.5	10.5	13	20
		700	–	–	(23)	–	(35)	–	(36)	(40)
80	80	700	–	–	(14)	–	(21)	–	(22)	(33)

Table 4.2: Fail-open valve · Valve closed with the required signal pressure

Bench range with actuator		240 cm ²	0.2 to 1.0			
		120 cm ² 350 cm ² 700 cm ²	1.2	2.4	4.0	
Nominal size DN	K _{Vs}	Actuator cm ²	Δp when $p_2 = 0$ bar			
15 to 25	1.6	120	9	40	–	
	2.5	240	28	40	–	
	4.0	350	40	40	–	
20 to 40	6.3 10.0	120	–	31	40	
		240	–	–	–	
		350	–	40	40	
		700	24	40	–	
32 to 50	16	240	–	27	40	
		350	5.2	40	40	
		700	13.5	40	–	
40 to 65	25	350	–	37	40	
		700	–	40	40	
50 to 80	40	350	–	23	40	
		700	–	40	40	
65 80	60	350	–	13	29	
		700	–	27	40	
80	80	700	–	16	37	

Table 5: Permissible differential pressure for Type 3275 Piston Actuator with Type 3241 PSA Valve**Table 5.1:** Plug with high-performance metal seal · Pressures in bar

Nominal size DN	Flow coefficient K_{vs}	Actuator cm^2	Supply pressure [bar]							
			1.4	2	2.5	3	3.5	4	5	6
20 to 40	6.3 to 10	314	40	–	–	–	–	–	–	–
32 to 50	16	314	26.5	40	–	–	–	–	–	–
		490	40	–	–	–	–	–	–	–
40 to 65	25	314	14.4	28.2	39.8	–	–	–	–	–
		490	32.5	40	–	–	–	–	–	–
50 to 65	40	314	6.1	14.8	22.0	29.3	35.5	40	–	–
		490	17.5	31.0	40	–	–	–	–	–
65	60	314	1.0	6.1	10.3	14.5	18.7	22.9	31.3	39.6
		490	7.6	15.5	22.0	28.6	35.1	40	–	–
80	40	314	6.0	14.7	21.9	29.1	36.4	40	–	–
		490	17.3	30.9	40	–	–	–	–	–
80	60	314	1.0	6.0	10.2	14.4	18.6	22.8	31.2	39.6
		490	7.5	15.4	22.0	28.5	35.1	40	–	–
80	80	314	–	1.9	4.5	7.2	9.8	12.4	17.6	22.8
		490	2.9	7.8	11.8	15.9	20.0	24.0	32.2	40
100	63	314	1.0	6.0	10.2	14.4	18.6	22.8	31.2	39.6
		490	7.5	15.4	22.0	28.5	35.1	40	–	–
		804	19.3	32.2	40	–	–	–	–	–
100 125	100	314	–	1.9	4.5	7.2	9.8	12.4	17.6	22.8
		490	2.9	7.8	11.8	15.9	20.0	24.0	32.2	40
		804	10.2	18.2	24.9	31.5	38.2	40	–	–
100 to 150	160	314	–	–	1.6	3.2	4.9	6.6	9.9	13.2
		490	0.5	3.6	6.2	8.8	11.4	14.0	19.2	24.4
		804	5.2	10.3	14.6	18.8	23.1	27.4	35.9	40
125	200	314	–	–	0.8	2.1	3.5	4.9	7.6	10.4
		490	–	–	4.6	6.8	8.9	11.1	15.4	19.6
		804	3.7	8.0	11.5	15.0	18.5	22.1	29.1	36.2
150	260	314	–	–	–	0.7	1.7	2.7	4.7	6.6
		490	–	1.0	2.5	4.1	5.6	7.1	10.2	13.3
		804	1.9	4.9	7.4	10.0	12.5	15.0	20.1	25.1

Table 5.2: Soft-seated plug - Pressures in bar

Nominal size DN	Flow coefficient K_{VS}	Actuator cm^2	Supply pressure [bar]							
			1.4	2	2.5	3	3.5	4	5	6
20 to 40	6.3 to 10	314	40	–	–	–	–	–	–	–
32 to 50	16	314	40	–	–	–	–	–	–	–
40 to 65	25	314	31.8	40	–	–	–	–	–	–
50 to 65	35	314	19.9	28.6	35.8	40	–	–	–	–
		490	31.2	40	–	–	–	–	–	–
65	60	314	11.4	16.5	20.7	24.9	29.1	33.3	40	–
		490	18.0	25.9	32.4	39.0	40	–	–	–
80	40	314	19.7	28.4	35.6	40	–	–	–	–
		490	31.1	40	–	–	–	–	–	–
80	60	314	11.1	16.5	20.7	24.9	29.1	33.3	40	–
		490	18.0	25.9	32.4	39.0	40	–	–	–
80	80	314	7.1	10.2	12.8	15.4	18.0	20.6	25.8	31.0
		490	11.2	16.0	20.1	24.2	28.2	32.3	40	–
100	63	314	11.4	16.5	20.7	24.9	29.1	33.3	40	–
		490	18.0	25.9	32.4	39.0	40	–	–	–
		804	29.8	40	–	–	–	–	–	–
100 125	100	314	7.1	10.2	12.8	15.4	18.0	20.6	25.8	31.0
		490	11.2	16.0	20.1	24.2	28.2	32.3	40	–
		804	18.4	26.4	33.1	39.8	40	–	–	–
100 to 150	160	314	4.5	6.5	8.2	9.8	11.5	13.2	16.5	19.8
		490	7.1	10.2	12.8	15.4	18.0	20.6	25.8	31.0
		804	11.8	16.9	21.2	25.4	29.7	34.0	40	–
125	200	314	3.7	5.4	6.8	8.1	9.5	10.9	13.6	16.4
		490	5.9	8.5	10.6	12.8	14.9	17.1	21.4	25.6
		804	9.7	14.0	17.5	21.0	24.5	28.1	35.1	40
150	260	314	2.7	3.8	4.8	5.8	6.8	7.8	9.8	11.7
		490	4.2	6.1	7.6	9.1	10.7	12.2	15.3	18.4
		804	7.0	10.0	12.5	15.0	17.6	20.1	25.1	30.2

Table 6: Dimensions for Type 3241-1 PSA, Type 3241-7 PSA and Type 3241-9 PSA in standard version

Valve	DN	15	20	25	32	40	50	65	80	100	125	150	
Length L	mm	130	150	160	180	200	230	290	310	350	400	480	
H1 for actuator	mm	220						260 ¹⁾					
H2 for version	Cast steel	40			72			98		118	144	175	
	Forged steel	53	-	70	-	92	98	-	128	-			

Actuator		Type 3271/3277					Type 3275				
Actuator area	cm ²	120	350	700	314	490	804				
Diaphragm Ø/□D	mm	Ø168	Ø280	Ø390	□220	□270	□350				
H	mm	69	85	199	201	220	286				
H3 ²⁾	mm	110		190	110		190				
H5	mm	88	101			101		-			
Thread		M30x1.5					M30x1.5		M60x1.5		
a (for Type 3271 Actuator)		G 1/8 (1/8 NPT)		G 3/8 (3/8 NPT)			G 3/8		G 1/2		
a2 (for Type 3277 Actuator)		-		G 3/8 (3/8 NPT)			-				

¹⁾ Add 65 mm to H1 when a Type 3275 Actuator with 804 cm² actuator area is mounted.

²⁾ Minimum clearance to remove the actuator

Table 7: Weights for Type 3241-1 PSA, Type 3241-7 PSA and Type 3241-9 PSA

Valve	DN	15	20	25	32	40	50	65	80	100	125	150
Weight without actuator	kg	5	6	7	11	12	15	24	30	42	80	120

Actuator		Type 3271			Type 3277			Type 3275		
Actuator area	cm ²	120	350	700	120	350	700	314	490	804
Weight, approx.	kg	3	8	22	3.5	12	26	10	17	21

Dimensional drawings

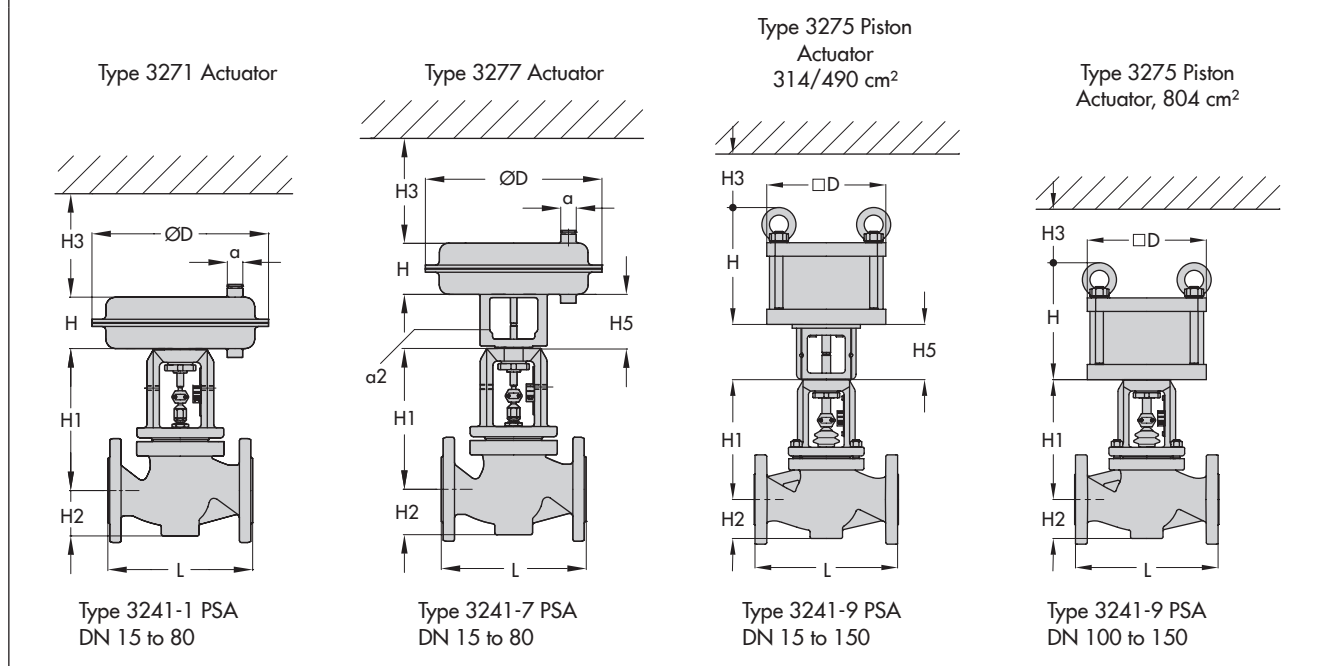

Ordering text

Globe valve	Type 3241 PSA
Nominal size	DN ...
Nominal pressure	PN ...
Body material	According to Table 2
Type of end connections	Flanges/welding ends
Seat/plug seal	Soft seal or high-performance metal seal
Characteristic	Equal percentage or linear
Actuator	Type 3271, Type 3277 or Type 3275 according to Data Sheet ► T 8310-1 EN or ► T 8314 EN
Fail-safe position	Fail-close or fail-open
Process medium	Density in kg/m ³ and temperature in °C
Flow rate	in kg/h or m ³ /h in standard or operating state
Pressure	p ₁ and p ₂ in bar (absolute pressure p _{abs}), with minimum, normal and maximum flow rate
Valve accessories	Positioner and/or limit switch

Specifications subject to change without notice



SAMSON AG · MESS- UND REGELTECHNIK
Weismüllerstraße 3 · 60314 Frankfurt am Main, Germany
Phone: +49 69 4009-0 · Fax: +49 69 4009-1507
samson@samson.de · www.samson.de

T 8015-1 EN

2014-10-13 · English