

Series 240

Type 3241-1 and Type 3241-7 Pneumatic Control Valves Type 3241 Globe Valve

ANSI version



Application

Control valve for process engineering and industrial applications

Valve size	NPS ½ to 12
Pressure rating	Class 125 to 300
Temperatures	-325 to 842 °F (-196 to 450 °C)



Type 3241 Globe Valve operated with

- Type 3271 Pneumatic Actuator (Type 3241-1 Control Valve) or
- Type 3277 Pneumatic Actuator (Type 3241-7 Control Valve)

Valve body made of

- Cast iron
- Cast steel, cast stainless steel or cast cold-resisting steel
- Forged steel or forged stainless steel
- Special materials

Undivided valve bonnet up to NPS 6

Valve plug

- Metal seal
- Soft seal
- High-performance metal seal

The control valves, designed according to the modular assembly principle, can be equipped with various accessories:

Positioners, limit switches, solenoid valves and other accessories according to IEC 60534-6-1 and NAMUR recommendation. Refer to Information Sheet ▶ T 8350 for more details.

Versions

Standard version for temperatures ranging from 15 to 430 °F (-10 to 220 °C)

- **Type 3241-1** (Fig. 1, Fig. 3) · NPS ½ to 12 with Type 3271 Pneumatic Actuator (▶ T 8310-1, ▶ T 8310-2, ▶ T 8310-3)
- **Type 3241-7** (Fig. 2, Fig. 4) · NPS ½ to 6 with Type 3277 Pneumatic Actuator for integral positioner attachment (▶ T 8310-1)

Further versions

- **NPT threaded connections** (Fig. 3) · NPS ½ to 2, Class 250
- **Adjustable packing** · See Information Sheet ▶ T 8000-1
- **Flow divider or AC-1/AC-2 Trim** for noise reduction · See Data Sheets ▶ T 8081 and ▶ T 8082
- **Valve plug with pressure balancing** · See Technical data
- **Insulating section or bellows seal** · See Technical data
- **Heating jacket** · On request
- **Stainless steel actuator** · See Data Sheet ▶ T 8310-1
- **Additional handwheel** · See Data Sheets ▶ T 8310-1, ▶ T 8310-2 and ▶ T 8310-3

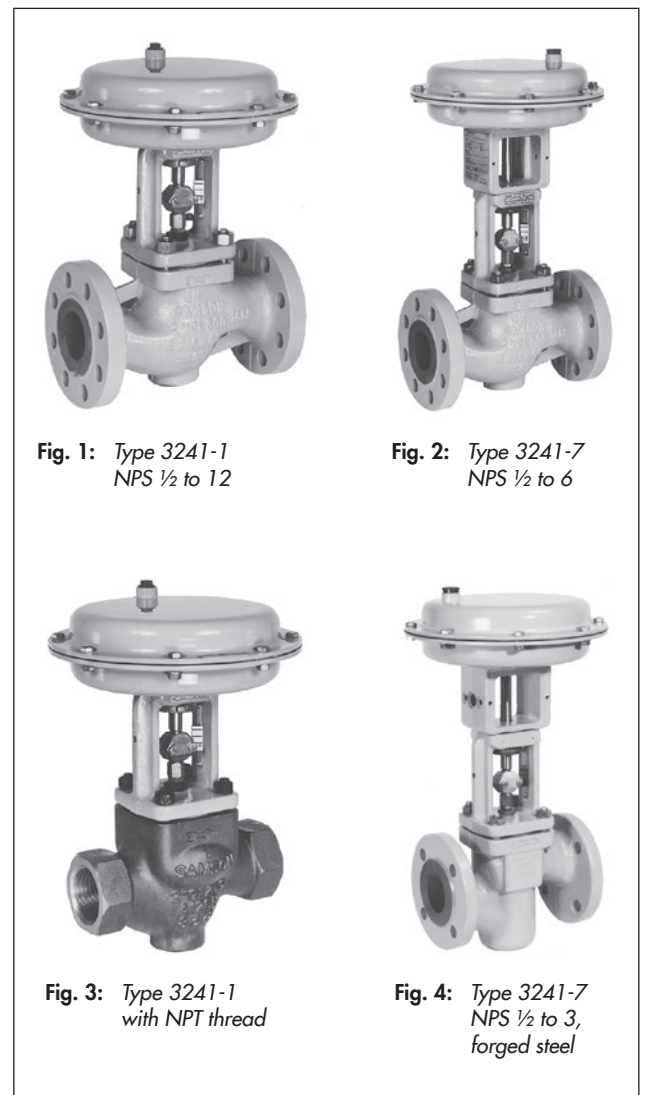

Fig. 1: Type 3241-1
NPS ½ to 12

Fig. 2: Type 3241-7
NPS ½ to 6

Fig. 3: Type 3241-1
with NPT thread

Fig. 4: Type 3241-7
NPS ½ to 3,
forged steel

- **Type 3241 PSA** · Version for pressure swing adsorption plants · See Data Sheets ▶ T 8012-1 and ▶ T 8015-1
- **Typetested version** · For heating systems (see ▶ T 8016), DIN/DVGW-tested version for gas (see ▶ T 8020) or liquid fuels and liquefied petroleum gas in the liquid phase (see ▶ T 8022)

Associated Information Sheet

T 8000-x

Edition September 2015

Associated Data Sheets for
pneumatic actuators

T 8310-x

Data Sheet

T 8012 EN

- **DIN version** (▶ T 8015)
- **Versions with dimensions according to Japanese Industry Standard (JIS)** · Details on request
- **NACE version** for sour gas applications · Details on request

Principle of operation

The medium flows through the valve in the direction indicated by the arrow. The valve plug position determines the cross-sectional area between the seat and plug.

Fail-safe position

Depending on how the springs are arranged in the pneumatic actuator (see Data Sheets ▶ T 8310-1, ▶ T 8310-2 and ▶ T 8310-3), the valve has two different fail-safe positions effective upon air supply failure.

Actuator stem extends (fail-close)

The valve closes when the supply air fails.

Actuator stem retracts (fail-open)

The valve opens when the supply air fails.



Note:

Figs. 5 and 8 show configuration examples. Permissible differential pressures are listed in Information Sheet ▶ T 8000-4.

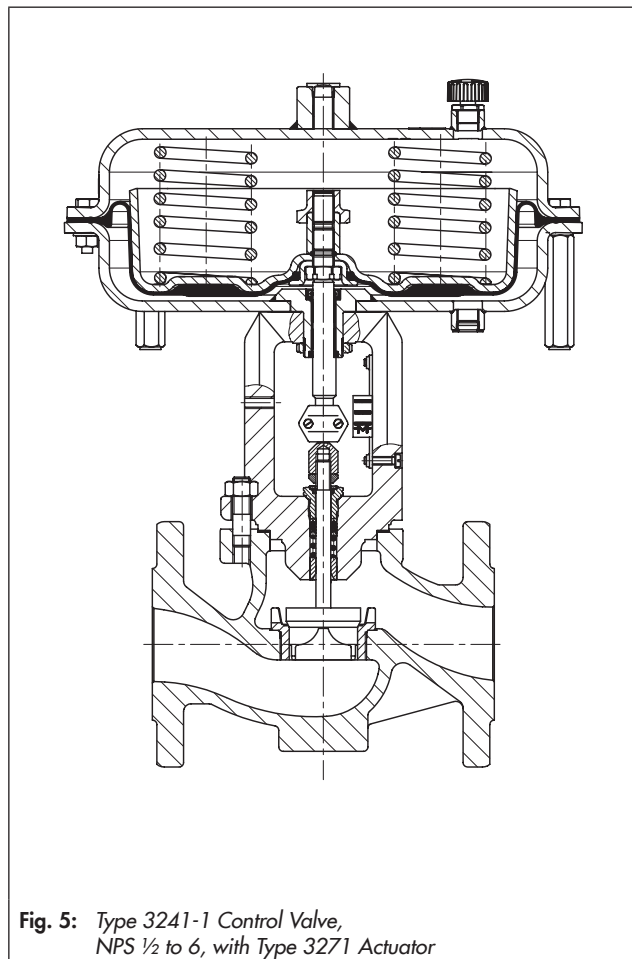

Fig. 5: Type 3241-1 Control Valve, NPS 1/2 to 6, with Type 3271 Actuator

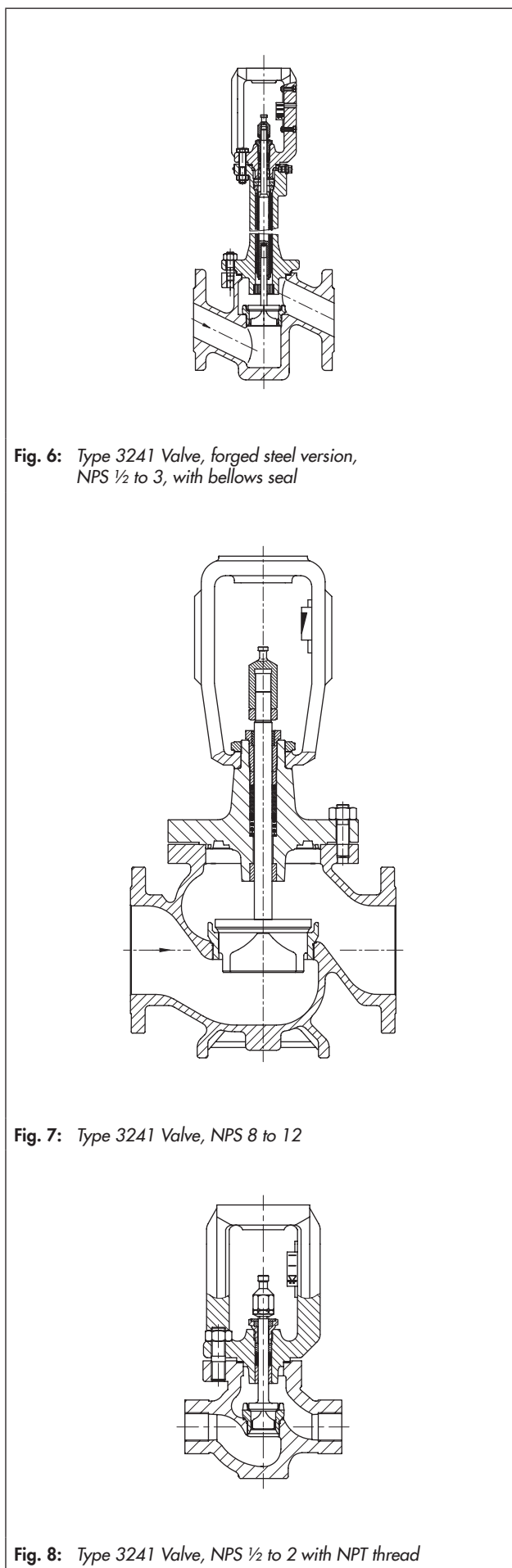

Fig. 6: Type 3241 Valve, forged steel version, NPS 1/2 to 3, with bellows seal

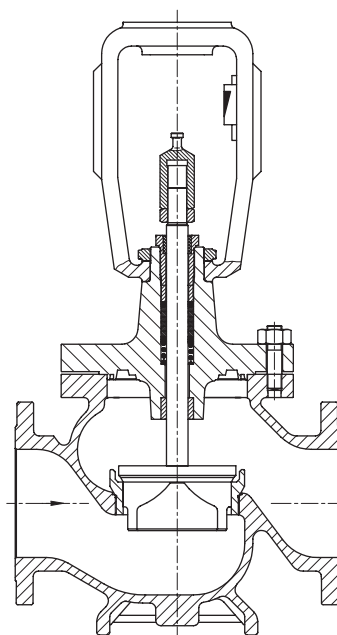

Fig. 7: Type 3241 Valve, NPS 8 to 12

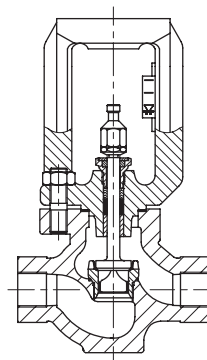

Fig. 8: Type 3241 Valve, NPS 1/2 to 2 with NPT thread

Table 1: Technical data

Valve size		NPS	1 to 6	½ to 2	½ to 12				½, 1, 1½, 2, 3 ²⁾	
ASTM material			Cast iron A 126 B		Cast steel A216 WCC	Cast stainless steel A351 CF8M	Cast steel A352 LCC	Cast stainless steel A351 CF8	Forged steel A105	Forged stainless steel A182 F316
Pressure rating	Class		125	250	150/300				300	
Type of end connections	Flanges		FF	-	RF ¹⁾				RF ¹⁾	
	Welding ends		-		DIN EN 12627 Fig. 2 only for NPS 1, 1½, 2, 3, 4, 6, 8, 10, 12				-	
	Thread		-	NPT	-				-	
Seat/plug seal		Metal seal · Soft seal · High-performance metal seal								
Characteristic		Equal percentage · Linear (according to Information Sheet ▶ T 8000-3)								
Rangeability		50:1 for NPS ½ to 2 · 30:1 for NPS 2½ to 6 · 50:1 for NPS 8 and larger								
Heating jacket		Class 150								
Temperature ranges in °C (°F) · Permissible operating pressures according to pressure-temperature diagram (see Information Sheet ▶ T 8000-2)										
Body without insulating section		-10 to 220 °C (15 to 430 °F)								
Body with	Insulating section	Short in °C (°F)	-29 to 232 (-20 to 449)	-29 to 427 (-20 to 800)	-50 to 450 (-58 to 842)	-46 to 343 (-50 to 650)	-50 to 300 (-58 to 572)	-29 to 427 (-20 to 800)	-50 to 450 (-58 to 842)	
		Long in °C (°F)	-	-	-196 to 450 (-325 to 842)	-	-196 to 300 (-325 to 572)	-	-196 to 450 (-325 to 842)	
	Bellows seal	Short in °C (°F)	-29 to 232 (-20 to 449)	-29 to 427 (-20 to 800)	-50 to 427 (-58 to 800)	-46 to 343 (-50 to 650)	-50 to 300 (-58 to 572)	-29 to 427 (-20 to 800)	-50 to 450 (-58 to 842)	
		Long in °C (°F)	-	-	-196 to 427 (-325 to 800)	-	-196 to 300 (-325 to 572)	-	-196 to 450 (-325 to 842)	
Valve plug	Standard	Metal seal	-196 to 450 °C (-325 to 842 °F)							
		Soft seal	-196 to 220 °C (-325 to 428 °F)							
	Balanced	With PTFE ring	-50 to 220 °C (-58 to 428 °F) · Lower temperatures on request							
		With graphite ring	220 to 450 °C (-58 to 842 °F)							
Leakage class according to ANSI/FCI 70-2										
Valve plug	Standard	Metal seal	Standard: IV · High-performance metal seal: V							
		Soft seal	VI							
	Balanced	Metal seal	Standard IV · With PTFE or balancing graphite ring Special version V · For high-performance metal seal (only with PTFE balancing ring) on request							

¹⁾ Other versions on request

²⁾ NPS 3 only in A 105

Table 2: Materials

Standard version							
Valve body ¹⁾	Cast iron A 126 B	Cast steel A216 WCC	Cast stainless steel A351 CF8M	Cast steel A352 LCC	Cast stainless steel A351 CF8	Forged steel A105	Forged stainless steel A182 F316
Valve bonnet	A 105/ A 126 B	A 105/ A216 WCC	A182 F316 A351 CF8M	A 350 LF2 A352 LCC	A182 F304 A351 CF8	A105	A182 F316
Seat ²⁾	Cr steel UNS S41000/1.4008		A182 F316L/ A351 CF3M	Cr steel UNS S41000/ 1.4008	A182 F304/ A351 CF8	Cr steel UNS S41000/ 1.4008	A182 F316L/ A351 CF3M
Plug ²⁾	Cr steel UNS S41000 (A182 F316L)/1.4008		A182 F316L/ A351 CF3M	Cr steel UNS S41000 (A182 F316L)/ 1.4008	A182 F304/ A351 CF8	Cr steel UNS S41000 (A182 F316L)/ 1.4008	A182 F316L/ A351 CF3M
Plug seal	Seal ring for soft-seated plug: PTFE with glass fiber						
	Seal ring for balanced plug: PTFE with carbon or graphite ring					-	
Guide bushings	A582 430 F		316 Ti	316 Ti	A182 F304	A582 430F	316 Ti
Packing ³⁾	V-ring packing: PTFE with carbon · Spring: A479 302						
Body gasket	Graphite on metal core						
Insulating section	A105	A105	A182 F316	A 350 LF2	A182 F304	A105	A182 F316
Metal bellows seal							
Intermediate piece	A105	A105	A182 F316	A 350 LF2	A182 F304	A105	A182 F316
Metal bellows	1.4571 ⁴⁾				A182 F321	1.4571	
Heating jacket	-	A182 F316L					

¹⁾ Special materials for applications with sea water: N 08904, duplex A 995 4 A; nickel-based alloy: A 494 LW-21M; other special materials on request

²⁾ Seats and metal-seated plug also with Stellite facing; for ≤ NPS 4 plug up to seat bore 38 made of solid Stellite available

³⁾ Other packings on request (▶ T 8000-1)

⁴⁾ Other materials on request

Table 3: C_V and K_{VS} coefficients

Table 3.1: Overview with flow divider St I (C_V I/ K_{VS} I), St II (C_V II/ K_{VS} II) or St III (C_V III/ K_{VS} III)

C_V	0.12	0.2	0.3	0.5	0.75	1.2	2	3	5	7.5	12	20	30	47	70	95	75	120	190	300	290	420	735	1150	1730	
K_{VS}	0.1	0.16	0.25	0.4	0.63	1.0	1.6	2.5	4.0	6.3	10	16	25	40	60	80	63	100	160	260	250	360	630	1000	1500	
C_V I	-	-	-	-	-	-	1.7	2.6	4.2	7	10.5	17	26	42	62	85	67	105	170	275	265	375	650	1040	1560	
K_{VS} I	-	-	-	-	-	-	1.45	2.2	3.6	5.7	9	14.5	22	36	54	72	57	90	144	234	225	320	560	900	1350	
C_V II	-	-	-	-	-	-	-	-	-	-	9.5	15	23	37	56	75	60	95	145	245	235	335	580	950	1400	
K_{VS} II	-	-	-	-	-	-	-	-	-	-	8	13	20	32	48	63	50	80	125	210	200	290	500	800	1200	
C_V III	-	-	-	-	-	-	-	-	-	-	9	14	23	35	-	-	55	90	140	-	220	315	560	880	1280	
K_{VS} III	-	-	-	-	-	-	-	-	-	-	7.5	12	20	30	-	-	47	75	120	-	190	270	480	750	1100	
Seat (ØD)	in	0.12		0.24			0.47			0.945			1.22	1.5	1.9	2.48	3.15	2.48	3.15	3.94	5.12	4.92	5.91	7.87	9.84	11.8
	mm	3		6			12			24			31	38	48	63	80	63	80	100	130	125	150	200	250	300
Travel	in	0.59															1.18			2.36			4.72			
	mm	15															30			60			120			

Table 3.2: Versions without flow divider (C_V/K_{VS}) · Areas highlighted in gray indicate versions also with pressure balancing

C_V	0.12	0.2	0.3	0.5	0.75	1.2	2	3	5	7.5	12	20	30	47	70	95	75	120	190	300	290	420	735	1150	1730		
K_{VS}	0.1	0.16	0.25	0.4	0.63	1.0	1.6	2.5	4.0	6.3	10	16	25	40	60	80	63	100	160	260	250	360	630	1000	1500		
NPS	DN																										
1/2	15	•	•	•	•	•	•	•	•	•																	
3/4	20	•	•	•	•	•	•	•	•	•																	
1	25	•	•	•	•	•	•	•	•	•	•																
1 1/2	40				•	•	•	•	•	•	•	•															
2	50				•	•	•	•	•	•	•	•	•														
2 1/2	65												•	•	•												
3	80												•	•	•	•		• ¹⁾									
4	100																•	•	•								
6	150																•	•	•	•							
8	200																	•	•		•	•	•				
10	250																		•	•		•	•	•	•		
12	300																			•		•	•	•	•	•	

¹⁾ With 19 mm overtravel (not for version with bellows seal)

Table 3.3: Versions with flow divider St I (C_V I/ K_{VS} I) · Areas highlighted in gray indicate versions also with pressure balancing

C_V I		-	1.7	2.6	4.2	7	10.5	17	26	42	62	85	67	105	170	275	265	375	650	1040	1560				
K_{VS} I		-	1.45	2.2	3.6	5.7	9	14.5	22	36	54	72	57	90	144	234	225	320	560	900	1350				
NPS	DN																								
1/2	15								•	•	•														
3/4	20								•	•	•														
1	25								•	•	•														
1 1/2	40									•	•	•	•												
2	50									•	•	•	•	•											
2 1/2	65												•	•	•										
3	80												•	•	•	•									
4	100														•	•	•	•							
6	150															•	•	•	•						
8	200																•	•		•	•	•			
10	250																	•	•		•	•	•	•	
12	300																		•		•	•	•	•	•

Table 3.1: Overview with flow divider St I (C_V I, K_{VS} I), St II (C_V II, K_{VS} II) or St III (C_V III, K_{VS} III)

C_V	0.12	0.2	0.3	0.5	0.75	1.2	2	3	5	7.5	12	20	30	47	70	95	75	120	190	300	290	420	735	1150	1730		
K_{VS}	0.1	0.16	0.25	0.4	0.63	1.0	1.6	2.5	4.0	6.3	10	16	25	40	60	80	63	100	160	260	250	360	630	1000	1500		
C_V I	-	-	-	-	-	-	1.7	2.6	4.2	7	10.5	17	26	42	62	85	67	105	170	275	265	375	650	1040	1560		
K_{VS} I	-	-	-	-	-	-	1.45	2.2	3.6	5.7	9	14.5	22	36	54	72	57	90	144	234	225	320	560	900	1350		
C_V II	-	-	-	-	-	-	-	-	-	-	9.5	15	23	37	56	75	60	95	145	245	235	335	580	950	1400		
K_{VS} II	-	-	-	-	-	-	-	-	-	-	8	13	20	32	48	63	50	80	125	210	200	290	500	800	1200		
C_V III	-	-	-	-	-	-	-	-	-	-	9	14	23	35	-	-	55	90	140	-	220	315	560	880	1280		
K_{VS} III	-	-	-	-	-	-	-	-	-	-	7.5	12	20	30	-	-	47	75	120	-	190	270	480	750	1100		
Seat (ØD)	in	0.12			0.24			0.47			0.945			1.22	1.5	1.9	2.48	3.15	2.48	3.15	3.94	5.12	4.92	5.91	7.87	9.84	11.8
	mm	3			6			12			24			31	38	48	63	80	63	80	100	130	125	150	200	250	300
Travel	in	0.59												1.18			2.36			4.72							
	mm	15												30			60			120							

Table 3.4: Versions with flow divider St II (C_V II/ K_{VS} II) · Areas highlighted in gray indicate versions also with pressure balancing

C_V II	-										9.5	15	23	37	56	-	60	95	145	245	250	335	580	950	1400		
K_{VS} II	-										8	13	20	32	48	-	50	80	125	210	200	290	500	800	1200		
NPS	DN																										
1/2	15																										
3/4	20																										
1	25																										
1 1/2	40																										
2	50																										
2 1/2	65																										
3	80																										
4	100																										
6	150																										
8	200																										
10	250																										
12	300																										

Table 3.5: Versions with flow divider St III (C_V III/ K_{VS} III) · Areas highlighted in gray indicate versions also with pressure balancing

C_V III	-										9	14	23	35	-	-	55	90	140	-	220	315	560	880	1280		
K_{VS} III	-										7.5	12	20	30	-	-	47	75	120	-	190	270	480	750	1100		
NPS	DN																										
1/2	15																										
3/4	20																										
1	25																										
1 1/2	40																										
2	50																										
2 1/2	65																										
3	80																										
4	100																										
6	150																										
8	200																										
10	250																										
12	300																										

¹⁾ Not with bellows seal or insulating section

Terms for control valve sizing according to IEC 60534, Parts 2-1 and 2-2: $F_1 = 0.95$, $X_T = 0.75$

Conversion of flow coefficients: C_V (US gallons/min.) = 1.17 K_{VS} (m³/h) · K_{VS} (m³/h) = 0.865 C_V (US gallons/min)

Table 4: Dimensions for standard version of Type 3241-1 and Type 3241-7 with flanges or welding ends

Table 4.1: Dimensions for Type 3241 Valve, up to NPS 6 · Without actuator

Valve		NPS	½	¾	1	1½	2	2½	3	4	6
		DN	15	20	25	40	50	65	80	100	150
		NPT	½	¾	1	1½	2	–	–	–	–
Length L ¹⁾	Class 125 and 150	in	7.25	7.25	7.25	8.75	10.0	10.88	11.75	13.88	17.75
		mm	184	184	184	222	254	276	298	352	451
	Class 300	in	7.50	7.62	7.75	9.25	10.50	11.50	12.50	14.50	18.62
		mm	190	194	197	235	267	292	318	368	473
Length L1	Class 250	in	6	6	6	8	9.25	–	–	–	–
		mm	152.4	152.4	152.4	203.2	235	–	–	–	–
H1 for actuator	≤ 750 cm ²	in	8.74			8.78		10.31		13.94	15.35
		mm	222			223		262		354	390
	1000 cm ² 1400-60 cm ²	in	–							16.26	17.72
		mm	–							413	450
	1400-120 cm ² 2800 cm ²	in	–								
		mm	–								
H2 for version	Cast steel	in	1.73	1.73	1.73	2.83	2.83	3.86	3.86	4.65	6.89
		mm	44	44	44	72	72	98	98	118	175
	Forged steel	in	2.1	–	2.76	3.62	3.86	–	5.05	–	–
		mm	53	–	70	92	98	–	128	–	–

¹⁾ Face-to-face dimensions according to ANSI/ISA 75.08.01

Table 4.2: Dimensions for Type 3241 Valve for NPS 8 and larger · Without actuator

Valve		NPS	8	10	10	10	12
		DN	200	250/cast iron	up to 200 mm seat bore	250 seat bore 250 mm and larger	300
Length L ¹⁾	Class 125 and 150	in	21.38	26.50	26.50	26.50	29.00
		mm	543	673	673	673	737
	Class 300	in	22.38	27.88	27.88	27.88	30.50
		mm	568	708	708	708	775
H4	in	15.35	15.35	17.76	17.76	25.67	
	mm	390	390	451	451	652	
H8 ²⁾ for actuator	1000 cm ² / 1400-60 cm ²	in	16.46	16.46	16.46	19.80	19.80
		mm	418	418	418	503	503
	1400-120 cm ² / 2800 cm ²	in	19.80	19.80	19.80	25.59	25.59
		mm	503	503	503	650	650
H2	in	9.65	10.63	12.20	12.20	14.57	
	mm	245	270	310	310	370	

¹⁾ Face-to-face dimensions according to ANSI/ISA 75.08.01

²⁾ H8 increases by 170 mm for valves with K_{VS} 250, 360 or 630 and 60 mm rated travel operating with overtravel.

Table 4.3: Dimensions for Types 3271 and 3277 Pneumatic Actuators

Actuator	cm ²	120	240	350	355	700	750	1000	1400-60	1400-120	2800
	in ²	18.60	37.20	54.25	55.03	108.50	116.25	155	217	217	434
Diaphragm ØD	in	6.61	9.45	11.02	11.02	15.35	15.35	18.19	20.87	21.02	30.32
	mm	168	240	280	280	390	390	462	530	534	770
H (700 cm ² and larger inc. lifting ring)	in	2.76	2.44	3.23	4.76	7.87	8.03	14.06	11.30	19.29	24.80
	mm	70	62	82	121	200	204	357	287	490	630
H3 ¹⁾	Type 3271	in	4.33			7.48		7.48/ 24.02	24.02	25.59	
		mm	110			190		190/610	610	650	
	Type 3277	in	4.33			7.48		-	-	-	-
		mm	110			190		-	-	-	-
H5	Type 3277	in	3.46	3.98			-	-	-	-	
		mm	88	101			-	-	-	-	
Thread	Type 3271	M30x1.5						M60x1.5		M100x2	
	Type 3277							-	-	-	-
a	Type 3271	G 1/8 (1/8 NPT)	G 1/4 (1/4 NPT)	G 3/8 (3/8 NPT)			G 3/4 (3/4 NPT)		G 1 (1 NPT)		
a2	Type 3277	-	G 3/8 (3/8 NPT)				-	-	-	-	

¹⁾ Minimum clearance required to remove the actuator

Table 4.4: Weights for Type 3241-1 and Type 3241-7 in standard version

Valve	NPS	1/2	3/4	1	1 1/2	2	2 1/2	3	4	6	8	10	12
	mm	15	20	25	40	50	65	80	100	150	200	250	300
Weight without actuator	lbs	15	18	20	35	44	71	82	137	287	1096	1892	2535
	kg	7	8	9	16	20	32	37	62	130	497	858	1150

Actuator	cm ²	120	240	350	355	700	750	1000	1400-60	1400-120	2800	
	in ²	18.6	37.2	54.25	55.0	108.5	116.3	155	217	217	434	
Type 3271 Actuator with handwheel	Without	lbs	6	11	18	33	49	79	176	154	386	992
		kg	2.5	5	8	15	22	36	80	70	175	450
	Travel ≤ 80 mm	lbs	-	20	29	51	60	90	397	386	661	1268
		kg	-	9	13	23	27	41	180	175	300	575
Travel ≤ 160 mm	lbs	-	-	-	-	-	-	-	-	937	1543	
	kg	-	-	-	-	-	-	-	-	425	700	
Type 3277 Actuator with handwheel	Without	lbs	7	20	26	42	57	88	-	-	-	
		kg	3.2	9	12	19	26	40	-	-	-	
	With	lbs	-	29	37	53	68	99	-	-	-	
		kg	-	13	17	24	31	45	-	-	-	

Table 5: Dimensions and weights for Type 3241 with insulating section or bellows seal

Table 5.1: Dimensions and weights for Type 3241 for NPS ½ to 6 and ½ to 2 NPT thread · Without actuator

Valve size		NPS	½	¾	1	1½	2	2½	3	4	6
		DN	15	20	25	40	50	65	80	100	150
Insulating section/bellows seal											
≤ 750 cm ²	Short	in	16.10			16.14		17.76		25.04	26.46
		mm	409			410		451		636	672
	Long	in	28.07			28.11		29.72		34.53	35.94
		mm	713			714		755		877	913
H4 for actuator	Short	in	-						27.36	28.82	
		mm	-						695	732	
	Long	in	-						36.85	38.31	
		mm	-						936	973	
1400-120 cm ² / 2800 cm ²	Short	in	-								
	Long	mm	-								
Weight without actuator (approx.)	Short	lbs	22	24	26	49	57	88	99	176	353
		kg	10	11	12	22	26	40	45	80	160
	Long	lbs	31	33	35	57	66	97	108	194	370
		kg	14	15	16	26	30	44	49	88	168

Table 5.2: Dimensions and weights for Type 3241 for NPS 8 to 12 · Without actuator

Version with		Insulating section				Metal bellows				
Valve size	NPS	8	10 up to 200 mm seat bore	10 Seat bore 250	12	8	10 up to 200 mm seat bore	10 Seat bore 250	12	
	DN	200	250 up to 200 mm seat bore	250 Seat bore 250	300	200	250 up to 200 mm seat bore	250 Seat bore 250	300	
H4 for actuator	1000/ 1400-60 cm ²	in	32.7	41.9	-	45.3	40.8	58.7	-	59.8
		mm	830	1065	-	1150	1036	1492	-	1520
	1400-120/ 2800 cm ²	in	32.7	41.9	41.9	45.3	40.8	58.7	58.7	59.8
		mm	830	1065	1065	1150	1036	1492	1492	1520
H8 for actuator	1000/ 1400-60 cm ²	in	16.5	16.5	19.8	19.8	16.5	16.5	19.8	19.8
		mm	418	418	503	503	418	418	503	503
	1400-120/ 2800 cm ²	in	19.8	19.8	25.6	25.6	19.8	19.8	25.6	25.6
		mm	503	503	650	650	503	503	650	650
Weight without actuator (approx.)	lbs	1191	2220	2220	2690	1312	2407	2407	2793	
	kg	540	1007	1007	1220	595	1092	1092	1267	

Table 6: Dimensions for Type 3241 with heating jacket - Not for valves in A 126 B

Valve size	NPS	1	1½/2	3	4	6	8 to 12
	DN	25	40/50	80	100	150	200 to 300
a	in	4.3	5.5	7.1	7.9	10.4	On request
	mm	110	140	180	200	265	
b	in	0.6	0.8	1.4	2	3.2	
	mm	15	20	35	50	80	
c	in	5.5	6.7	8.5	10	5.1	
	mm	140	170	215	255	130	
d	in	7.5	7.5	9.1	12.6	14	
	mm	190	190	230	320	355	

Dimensional drawings

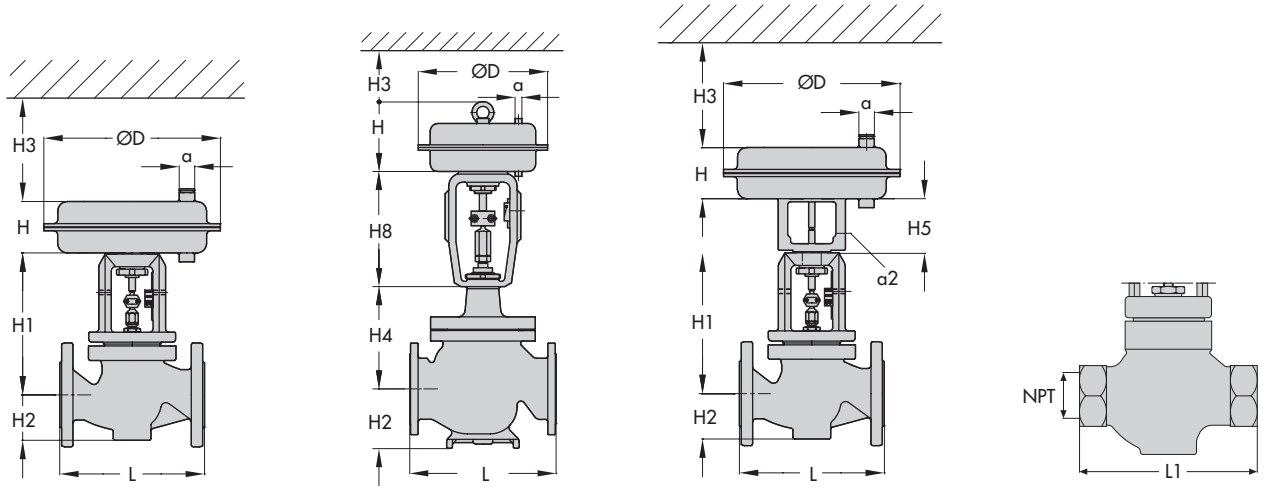

Type 3241-1 · NPS ½ to 6

Type 3241-1 · NPS 8 to 12

Type 3241-7 · NPS ½ to 6

Type 3241 · ½ to 2 NPT

Versions with insulating section or bellows seal

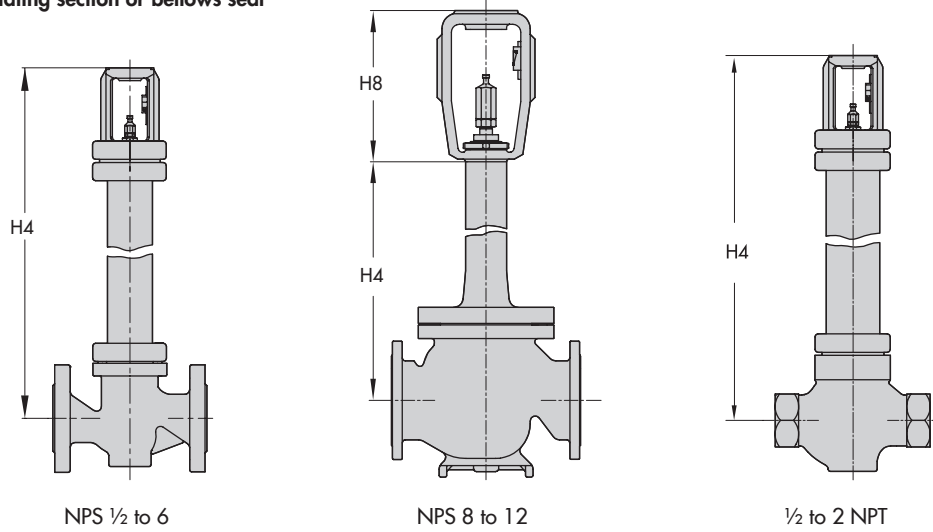

NPS ½ to 6

NPS 8 to 12

½ to 2 NPT

Versions with heating jacket

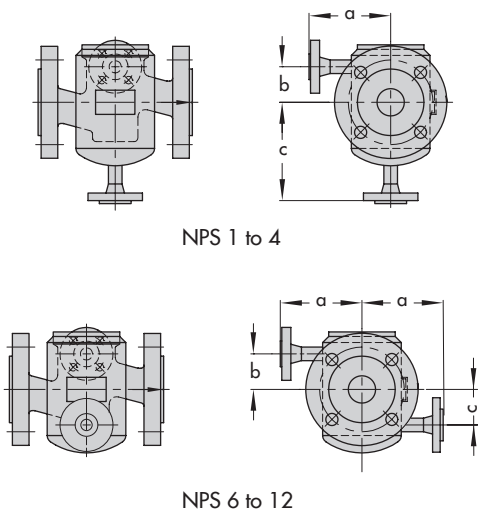

NPS 1 to 4

NPS 6 to 12

Versions with insulating section or bellows seal

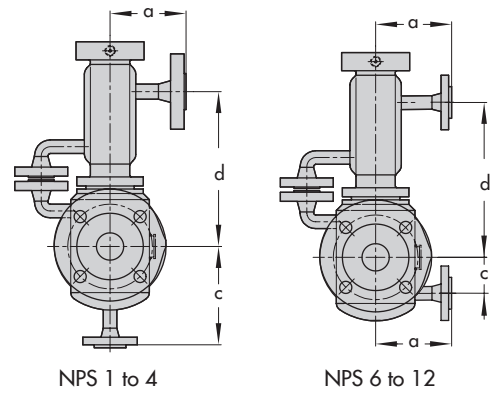

NPS 1 to 4

NPS 6 to 12

Ordering text

Globe valve	Type 3241
Valve size	NPS ...
Pressure rating	Class ...
Body material	According to Table 2
Type of end connections	Flanges (RF or FF), welding ends or NPT thread
Seat and plug	Metal seal/soft seal/high-performance metal seal
Characteristic	Equal percentage or linear
Pneumatic actuator	Type 3271 or Type 3277
Fail-safe position	Fail-close or fail-open
Process medium	Density and temperature
Max. flow rate	in kg/h oder m ³ /h
Pressure	p ₁ and p ₂ in bar or psi (absolute pressure)
Valve accessories	Positioner and/or limit switch

Specifications subject to change without notice



SAMSON AG · MESS- UND REGELTECHNIK
Weismüllerstraße 3 · 60314 Frankfurt am Main, Germany
Phone: +49 69 4009-0 · Fax: +49 69 4009-1507
samson@samson.de · www.samson.de

T 8012 EN

2015-09-11 · English