

## Application

Limit monitoring of differential pressure, pressure and vacuum (draught).

Designed for liquids, gases and steams as well as differential pressure, pressure and vacuum set points from 35 to 400 mbar with operating pressures up to 10 bar.

The differential pressure switches are limit switches which issue an electrical limit signal whenever a certain limit of the differential pressure, pressure or vacuum is reached. This signal is used to control an audible or visual alarm, signal processing and closed or open-loop control equipment.

Type 4738 Differential Pressure Switch is used, for example in heating plants utilizing hot-water priority circuit, and is overloadable on one side up to 10 bar. The maximum permissible temperature of the process medium is 80 °C.

## Versions

**Type 4738** (Fig. 1) · Differential pressure switch with adjustable limit values from  $\Delta p = 35$  to 160 mbar or from 160 to 400 mbar

## Ordering text

Type 4738 Electric Differential Pressure Switch

Setting range  $\Delta p$  ... to ... mbar

Operating pressure ... bar

Safety pressure limiter, see SAMSOMATIC T 758-4 EN.

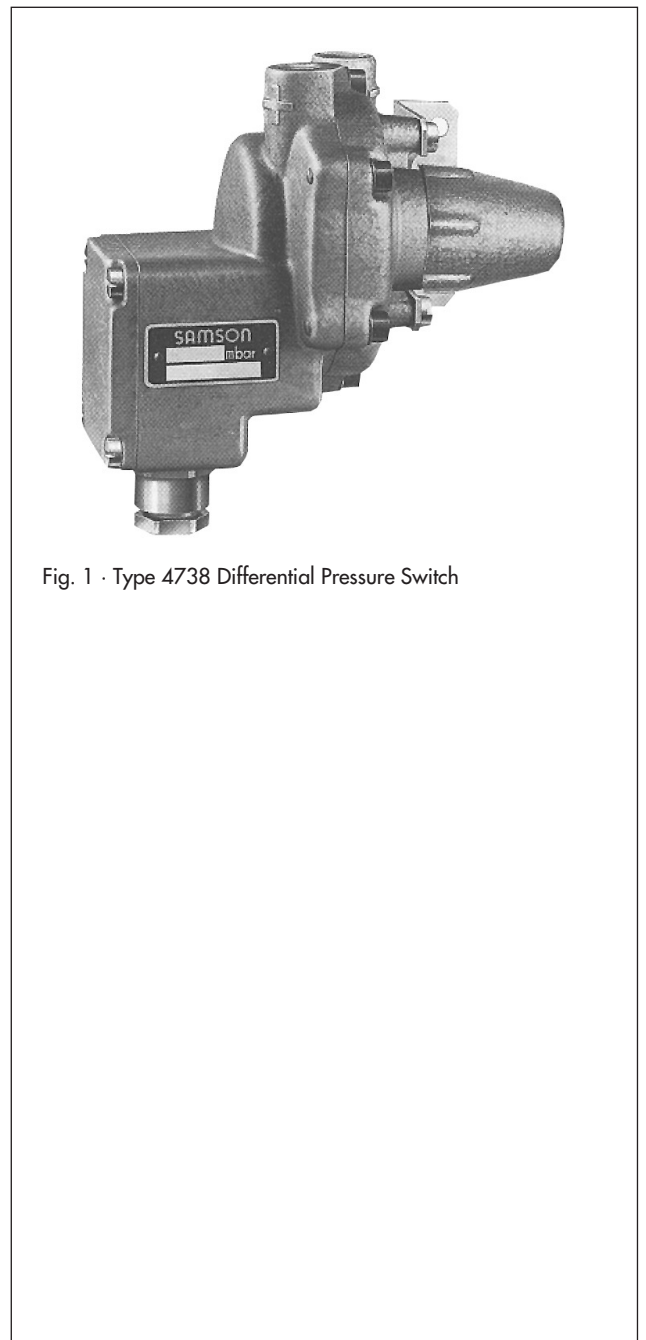

Fig. 1 · Type 4738 Differential Pressure Switch

## Principle of operation

The differential pressure switch is equipped with a differential pressure cell containing spring-loaded measuring diaphragm.

The differential pressure, pressure or vacuum produce a force acting on the diaphragm which is balanced by the range spring. If the force produced on the diaphragm exceeds the spring compression, the integrated switch is activated, i.e. the range spring compression determines the limit of the differential pressure switch.

## Installation

The differential pressure switch must be installed according to the dimensional drawing. The pressure connections are located at the top, electrical connections at the bottom.

To monitor the pressure, only the positive (+) connection (negative connection (-) open) is connected to the measuring point. To monitor the vacuum (draught) only the negative connection (-) (positive (+) connection open) is connected to the measuring point. The wiring is to be performed according to the wiring diagram and the signal or control equipment to be connected.

## Wiring diagram

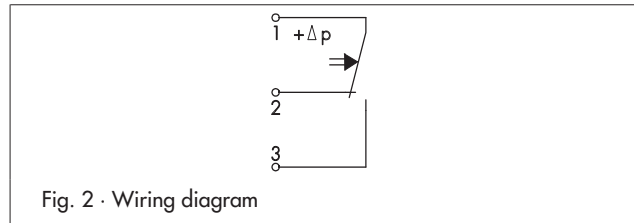
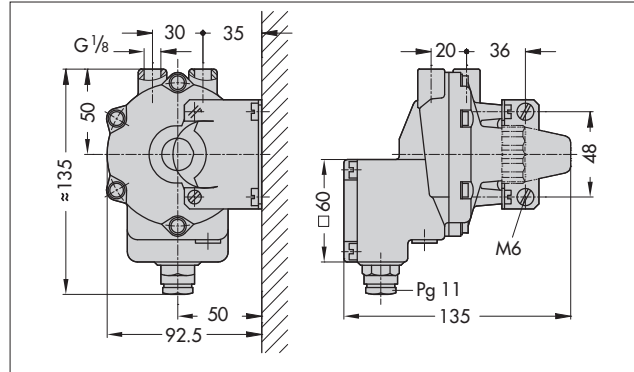

Fig. 2 · Wiring diagram

## Dimensions in mm



## Technical data

Differential Pressure Switch	Type 4738
Limits	Continuously adjustable
Differential pressure ( $\Delta p$ )	35 to 160 mbar or 160 to 400 mbar
Max. on-off differential	For limits $\leq$ 100 mbar: 15 mbar For limits $>$ 100 mbar: 25 mbar
Max. permissible operating pressure	10 bar, short-term overload up to 16 bar
Overload capacity one side max.	10 bar
Perm. temperature of process medium max.	80 °C
Materials coming into contact with the medium	Housing: GD AlSi12 Diaphragm: Perbunan
Switch capacity	250 V~, 5 A with resistive load
Ambient temperature	Max. 50 °C
Degree of protection	IP 54
Weight	Approx. 1 kg

Specifications subject to change without notice

