

Self-operated Pressure Regulators

Universal Pressure Reducing Valve

Type 41-23



ANSI version

Application

Pressure regulators for set points from **0.075 to 400 psi (5 mbar to 28 bar)** · Valves in **NPS ½ to 4 (DN 15 to 100)** · Pressure rating **Class 125 to 300 (PN 16 to 40)** · Suitable for water, gases and vapors up to **660 °F (350 °C)**

The valve **closes** when the downstream pressure rises



Special features

- Low-maintenance proportional regulators requiring no auxiliary energy
- Frictionless plug stem seal with stainless steel bellows
- Control line kit available for tapping the pressure directly at the valve body
- Wide set point range and easy set point adjustment over a nut
- Exchangeable actuator and positioning springs
- Spring-loaded, single-seated valve with upstream and downstream pressure balancing¹⁾ by a stainless steel bellows
- Plug with soft sealing for high sealing requirements
- Low-noise standard plug · Special version with a flow divider St I or St III (NPS 1½ to 4/DN 65 to 100) for further noise level reduction (see Data Sheet T 8081 EN)

Versions

Pressure reducing valve for controlling the downstream pressure p_2 to the adjusted set point. The valve closes when the downstream pressure rises.

Type 41-23 · Standard version

Type 2412 Valve · Valve in NPS ½ to 4 (DN 15 to 100) · Plug with metal sealing · Body made of either cast iron A126B, carbon cast steel A216WCC or stainless carbon steel A351 CF8M

Type 2413 Actuator with EPDM rolling diaphragm and screw fitting · All wetted parts are free of non-ferrous metal

Extended versions

Millibar pressure reducing valve (NPS ½ to 3/DN 15 to 80) for pressure set points from 0.075 to 0.75 psi (5 to 50 mbar)

Pressure reducing valve for small flow rates

Valve with micro-trim ($C_v = 0.0012$ to $0.05/K_{VS} = 0.001$ to 0.04) or special C_v/K_{VS} (reduced cross-sectional flow area)

Steam pressure reducing valve

with condensation chamber for steam up to 660 °F (350 °C)

Safety pressure reducing valve

with leakage line connection and seal or two diaphragms and diaphragm rupture indicator

¹⁾ For $C_v \leq 3/K_{VS} \leq 2.5$: without balancing bellows



Type 41-23 - without control line -

Fig. 1 · Type 41-23 Universal Pressure Reducing Valve

Special versions

- Control line kit for pressure tapping at the valve body (accessories)
- FPM rolling diaphragm for oils
- Free of oil and grease for oxygen with NBR diaphragm
- EPDM diaphragm with PTFE protective foil
- Actuator for remote set point adjustment (autoclave control)
- Bellows actuator for valves NPS ½ to 4 (DN 15 to 100) · Set point ranges 30 to 85 psi; 75 to 150 psi; 150 to 300 psi, 300 to 400 psi (2 to 6, 5 to 10, 10 to 22, 20 to 28 bar)
- Valve with flow divider St I or St III (NPS 2½ to 4/DN 65 to 100) for particularly low-noise operation with gases and vapors
- Version completely in stainless steel
- Stainless Cr steel seat and plug with PTFE soft sealing (max. 440 °F/max. 220 °C) · With EPDM soft sealing (300 °F/max. 150 °C)

- Seat and plug armored for low-wear operation
- Free of lubricants for high-purity water/gas
- Free of oil and grease for high-purity applications
- Wetted plastic parts conforming to FDA regulations (max. 140 °F/max. 60 °C)

Principle of operation (see Fig. 2)

The medium flows through the valve (1) as indicated by the arrow. The position of the valve plug (3) and the area released between the plug and seat (2) determine the flow rate. The plug stem (5) with the plug is connected to the stem (11) of the actuator (10).

To control the pressure, the operating diaphragm (12) is tensioned by the positioning springs (7) and the set point adjustment nut (6) so that the valve is opened by the force of the positioning springs when it is relieved of pressure ($p_1 = p_2$).

The downstream pressure p_2 to be controlled is tapped downstream of the valve and transmitted via the control line (14) to the operating diaphragm (12) where it is converted into a positioning force. This force is used to move the valve plug (3) according to the force of the positioning springs (7), which is adjustable at the set point adjustment nut (6). When the force resulting from the downstream pressure p_2 rises above the adjusted set point, the valve closes proportionally to the change in pressure.

The fully balanced valves are equipped with a balancing bellows (4). The downstream pressure p_2 acts on the inside of the bellows, whereas the upstream pressure p_1 acts on the outside of the bellows. As a result, the forces produced by the upstream and downstream pressures acting on the plug are balanced.

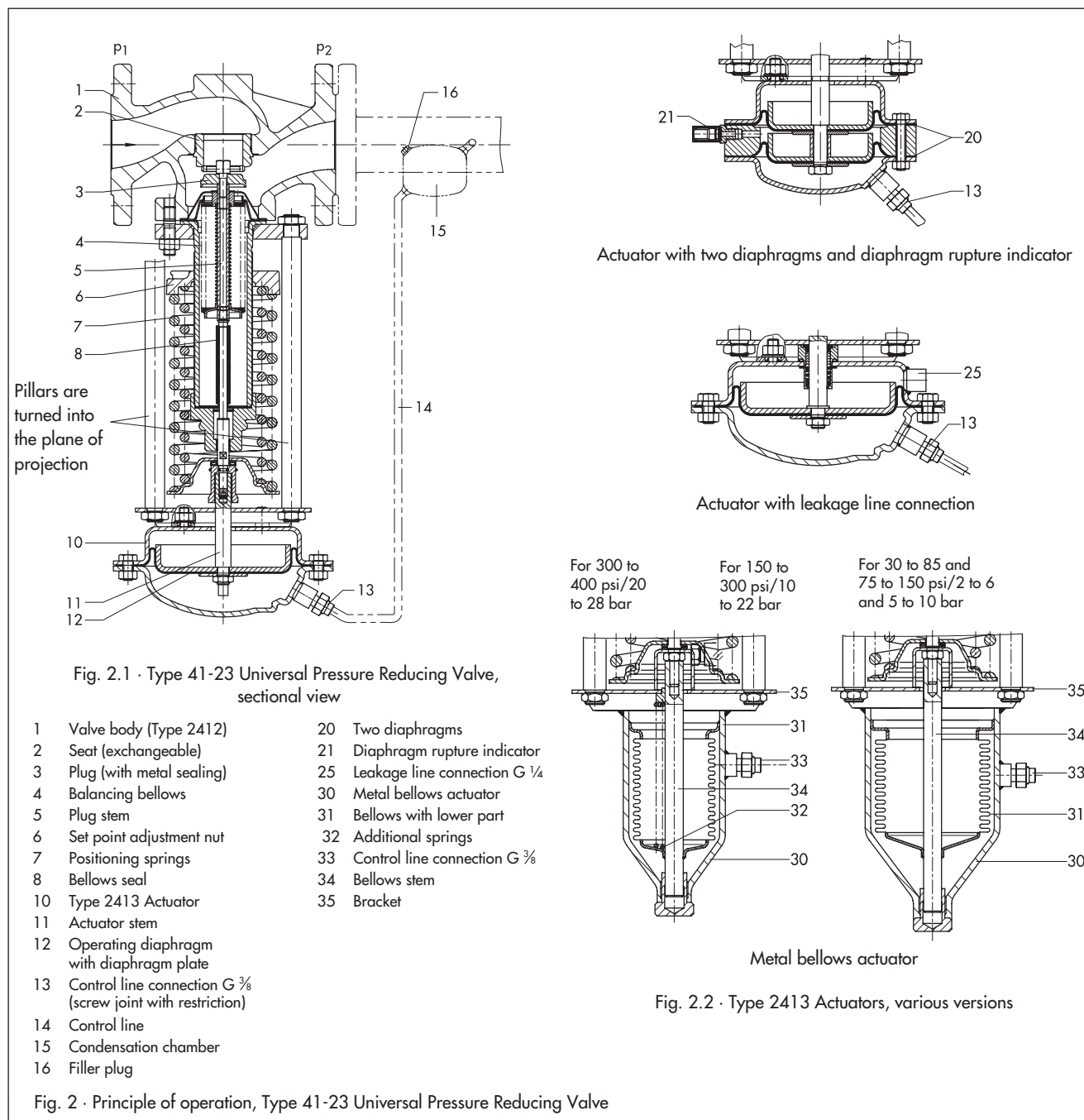

Fig. 2 · Principle of operation, Type 41-23 Universal Pressure Reducing Valve

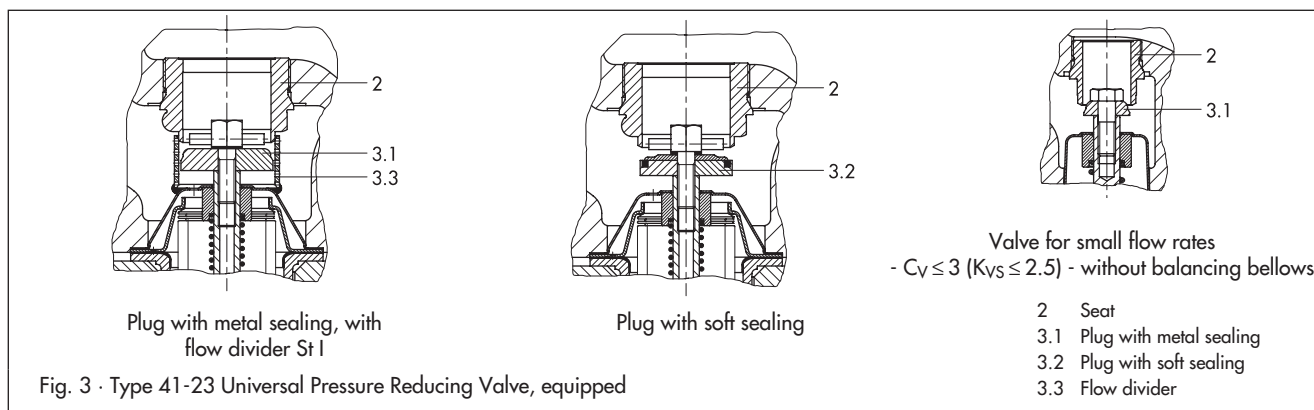

Table 1 · Technical data · All pressures specified as gauge pressure

Valve		Type 2412		
Pressure rating	Class	125, 150 or 300		
	PN	16, 25 or 40		
Nominal size	NPS	½ to 2	2 ½ and 3	4
	DN	15 to 50	65 to 80	100
Max. perm. diff. pressure Δp	psi	360 ¹⁾	290 ¹⁾	230
	bar	25 ¹⁾	20 ¹⁾	16
Temperature ranges		See Fig. 6 · Pressure-temperature diagram		
	Valve plug	Metal sealing: max. 660 °F (350 °C) · PTFE soft sealing: max. 430 °F (220 °C) · EPDM, FPM soft sealing: max. 300 °F (150 °C) · NBR soft sealing: max. 140 °F (60 °C)		
Leakage rate (standard version)		Metal sealing: Leakage rate I ≤ 0.05 % of C_v/K_{vs} · Soft sealing: Leakage rate IV		
Actuator with diaphragm		Type 2413		
Set point ranges		0.075 to 0.42 psi ²⁾ · 0.35 to 0.75 psi ²⁾ · 0.75 to 3.5 psi · 1.5 to 8.5 psi · 3 to 17 psi · 10 to 35 psi · 30 to 75 psi · 65 to 145 psi · 115 to 230 psi		
		5 to 30 mbar ²⁾ · 25 to 50 mbar ²⁾ · 0.05 to 0.25 bar · 0.1 to 0.6 bar · 0.2 to 1.2 bar · 0.8 to 2.5 bar · 2 to 5 bar · 4.5 to 10 bar · 8 to 16 bar		
Max. perm. pressure at actuator		1.5 times max. set point of the actuator used ³⁾		
Max. perm. temperature		Gases 660 °F (350 °C), however, max. 175 °F (80 °C) at the actuator · Liquids 300 °F (150 °C), with condensation chamber max. 660 °F (350 °C) · Steam with condensation chamber max. 660 °F (350 °C)		
Actuator with bellows		Type 2413		
Effective area		5.1 sq.in (33 cm ²)	9.6 sq.in (62 cm ²)	
Max. perm. pressure at actuator		435 psi (30 bar)	290 psi (20 bar)	
Set point ranges		150 to 300 psi (10 to 22 bar)	30 to 85 psi (2 to 6 bar) ⁴⁾	
		300 to 400 psi (20 to 28 bar)	75 to 150 psi (5 to 10 bar)	
Set point spring		8000 N		

¹⁾ For millibar pressure reducing valve, max. perm. differential pressure Δp : 10 bar · ²⁾ For millibar pressure reducing valve only

³⁾ Millibar pressure reducing valve: max. 0.5 bar · ⁴⁾ Set point spring 4400 N

Table 2 · Materials

Valve		Type 2412		
Pressure rating		Cl 125 (PN 16)	Cl 150 (PN 25) · Cl 300 (PN 40)	Cl 150 (PN 25) · Cl 300 (PN 40)
Max. perm. temperature		570 °F (300 °C)	660 °F (350 °C)	660 °F (350 °C)
Body		Cast iron A126B	Carbon steel A216 WCC	Stainless carbon steel A351 CF8M
Seat		CrNi steel		CrNiMo steel
Plug		CrNi steel		CrNiMo steel
	Seal ring for soft seal	PTFE with 15 % glass fiber · EPDM · NBR · FPM		
Guide bushing		PTFE/Graphite		
Balancing bellows and bellows seal		Stainless forged steel 1.4571		
Actuator		Type 2413		
Diaphragm cases		Sheet steel DD11 (StW22) ¹⁾		
Diaphragm		EPDM with fabric insert ²⁾ · FPM for oils · NBR · EPDM with PTFE protective foil		

¹⁾ In stainless steel version, CrNi steel · ²⁾ Standard version; further details in "Special versions"

Table 3 · C_V (K_{VS}) coefficients and z values

Nom. size NPS · DN	Seat Ø		C _V · K _{VS} ²⁾				C _V I · K _{VS} I ¹⁾		C _V III · K _{VS} III ¹⁾		z ¹⁾
	inch	mm	Standard version		Special version		With flow divider				
			C _V	K _{VS}	C _V	K _{VS}	C _V I	K _{VS} I	C _V III	K _{VS} III	
½ · 15	0.24	6			0.12 · 0.5 · 1.2	0.1 · 0.4 · 1	–	–			
	0.87	22	5	4	3	2.5	3.5	3	–	–	0.65
¾ · 20	0.24	6			0.12 · 0.5 · 1.2	0.1 · 0.4 · 1					
	0.87	22			3 · 5	2.5 · 4	–	–	–	–	
7.5			6.3			6	5			0.6	
1 · 25	0.24	6			0.12 · 0.5 · 1.2	0.1 · 0.4 · 1	–	–			
	0.87	22					–	–			
9.4			8	3 · 5 · 7.5	2.5 · 4 · 6.3	7	6	–	–	0.55	
1½ · 40	1.57	40			7.5 · 9.4 · 20	6.3 · 8 · 16					
			23	20			17	15	–	–	0.45
2 · 50	1.57	40			9.4 · 20 · 23	8 · 16 · 20					
			37	32			30	25	–	–	0.4
2½ · 65	2.56	65			23 · 37	20 · 32					
			60	50			45	38	30	25	0.4
3 · 80	2.56	65			37 · 60	32 · 50					
			94	80			70	60	46	40	0.35
4 · 100	3.50	89			60	50					
			145	125			110	95	70	60	0.35

¹⁾ Terms for noise level calculation according to VDMA 24422 (edition 1.89)

²⁾ For C_V 0.0012 to 0.05/K_{VS} 0.001 to 0.04: Valve with micro-trim without balancing bellows

Valve-specific correction terms

ΔL_G · For gases and vapors:

Values as specified in the diagram in Fig. 4

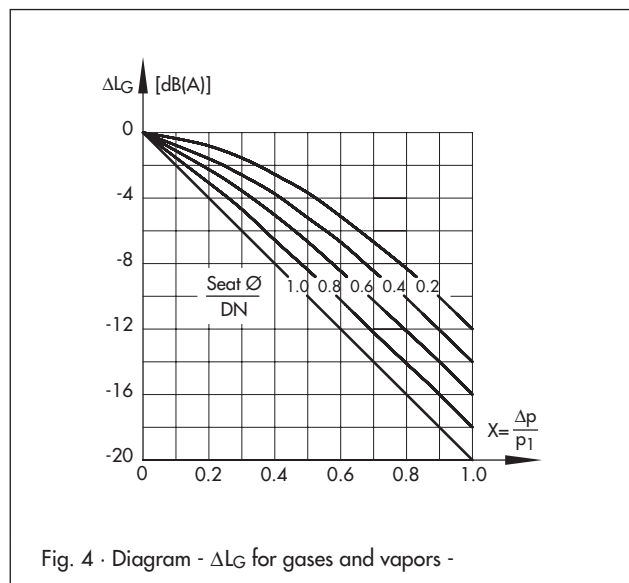

Fig. 4 · Diagram - ΔL_G for gases and vapors -

ΔL_F · For liquids:

$$\Delta L_F = -10 \cdot (X_F - z) \cdot y$$

$$\text{with } X_F = \frac{\Delta p}{p_1 - p_v} \text{ and } y = \frac{K_v}{K_{vs}}$$

Terms for control valve sizing according to DIN EN 60534, Parts 2-1 and 2-2:

$$F_L = 0.95 \quad X_T = 0.75$$

z · Acoustical valve coefficient

K_{VS} I, K_{VS} III · For installation of a flow divider St I or St III as a noise-reducing component · Flow characteristic differences between valves with and valves without flow dividers do not occur until the valve has passed through approx. 80 % of its travel range.

Table 4 · Dimensions and weights

Pressure reducing valve			Type 41-23								
Nominal size NPS (DN)			½ (15)	¾ (20)	1 (25)	1½ (40)	2 (50)	2½ (65)	3 (80)	4 (100)	
Length L	Cl 125	inch	–	–	7.25	8.75	10.0	10.87	11.75	13.87	
		mm	–	–	184	222	254	276	298	352	
	Cl 150	inch	7.25	7.25	7.25	8.75	10.0	10.87	11.73	13.88	
		mm	184	184	184	222	254	276	298	352	
	Cl 300	inch	7.50	7.63	7.75	9.25	10.50	11.50	12.50	14.50	
		mm	191	194	197	235	267	292	318	368	
Height H1	inch	13.19			15.35		20.08		20.67		
	mm	335			390		510		525		
Height H3	inch	2.17			2.83		3.94		4.73		
	mm	55			72		100		120		
Set point ranges		Dimensions		Dimensions in inches and mm ()							
psi	bar										
0.075 to 0.42	0.005 to 0.03	Height H		17.13" (435 mm)							
		Actuator		∅ D = 19.29" (490 mm), A = 186 in ² (1200 cm ²)							
		Valve spring force F		600 N							
0.35 to 0.75	0.025 to 0.05	Height H		17.13" (435 mm)		19.29" (490 mm)		24" (610 mm)			
		Actuator		∅ D = 19.3" (490 mm), A = 186 in ² (1200 cm ²)							
		Valve spring force F		1200 N							
0.75 to 3.5	0.05 to 0.25	Height H		17.52 (445 mm)		19.68" (500 mm)		24.41" (620 mm)		25" (635)	
		Actuator		∅ D = 15" (380 mm), A = 100 in ² (640 cm ²)							
		Valve spring force F		1750 N							
1.5 to 8.5	0.1 to 0.6	Height H		17.52" (445 mm)		19.68" (500 mm)		24.41" (620 mm)		25" (635)	
		Actuator		∅ D = 15" (380), A = 100 in ² (640 cm ²)							
		Valve spring force F		4400 N							
3 to 17	0.2 to 1.2	Height H		16.93" (430 mm)		19.90" (480 mm)		23.62" (600 mm)		24.41"(620)	
		Actuator		∅ D = 11.2" (285), A = 50 in ² (320 cm ²)							
		Valve spring force F		4400 N							
10 to 35	0.8 to 2.5	Height H		16.93" (430 mm)		18.09" (485 mm)		23.82" (605 mm)		24.41"(620)	
		Actuator		∅ D = 8.86" (225), A = 25 in ² (160 cm ²)							
		Valve spring force F		4400 N							
30 to 75	2 to 5	Height H		16.14" (410 mm)		18.31" (465 mm)		23.03" (585 mm)		23.62"(600)	
		Actuator		∅ D = 6.69" (170 mm), A = 12 in ² (80 cm ²)							
		Valve spring force F		4400 N							
65 to 150	4.5 to 10	Height H		16.14" (410 mm)		18.31" (465 mm)		23.03" (585 mm)		23.62"(600)	
		Actuator		∅ D = 6.69" (170 mm), A = 6 in ² (40 cm ²)							
		Valve spring force F		4400 N							
115 to 230	8 to 16	Height H		16.14" (410 mm)		18.31" (465 mm)		23.03" (585 mm)		23.62"(600)	
		Actuator		∅ D = 6.69" (170 mm), A = 6 in ² (40 cm ²)							
		Valve spring force F		8000 N							
0.075 to 0.75	0.005 to 0.05		lb	63	65	82.7	90.4	125.7	141	–	
			kg	28.5	29.5	37.5	41	57	64	–	
1.5 to 8.3	0.05 to 0.6	Weight, for Class 150 ¹⁾ , approx.	lb	39	51.8	69.4	77.2	112.4	128	147	
			kg	22.5	23.5	31.5	35	51	58	67	
3 to 35	0.2 to 2.5		lb	35.3	39.7	56.2	64	99.2	114.6	134.5	
			kg	16	18	25.5	29	45	52	61	
30 to 230	2 to 16		lb	26.5	28.7	46.3	60	88.2	103.6	123.5	
			kg	12	13	21	24	40	47	56	

¹⁾ +10 % for Class 300

**Type 41-23
Universal Pressure
Reducing Valve**

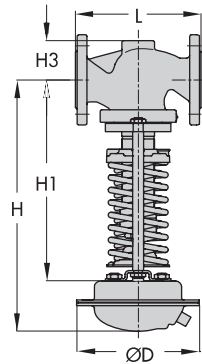
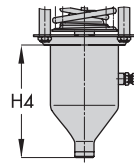

Fig. 5 · Dimensions



**Type 2413
Actuator with metal
bellows**

Height		
Effective dia. area	5.1 in ² (33 cm ²)	9.6 in ² (62 cm ²)
H4	7.9 in (200 mm)	8.5 in (215 mm)
Weight		
NPS ½ to 2 (DN 15 to 50)	17.6 lb (8 kg)	37.5 lb (17 kg)
NPS 2½ to 4 (DN 65 to 100)	26.5 lb (12 kg)	39.7 lb (18 kg)

Installation

Normally, the valve is installed with the actuator suspended downwards. Install pipelines horizontally with a slight downward slope on both sides of the valve for drainage of the condensate.

Millibar pressure reducing valves are to be installed standing upright with the actuator pointing upwards.

For further details on installation, refer to Mounting and Operating Instructions EB 2512 EN.

The direction of medium flow must correspond with the arrow on the valve body.

- Valve and actuator are delivered separately.
- The control line must be adapted to match the onsite conditions and is not delivered with the valve; on customer request, a control line kit for the direct pressure tapping at the valve body (see accessories) is available.

Pressure-temperature diagram – ASTM materials –

The range of application of the valves and the permissible pressures and temperatures are limited by the pressure-temperature diagram and the nominal pressure ratings.

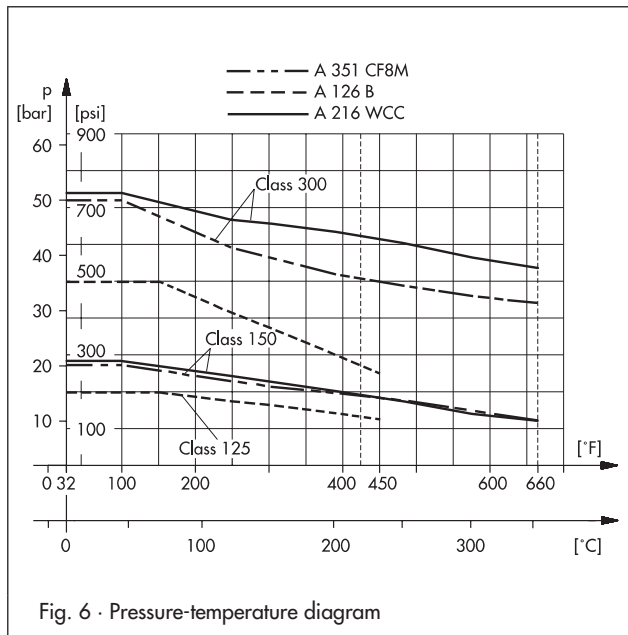

Fig. 6 · Pressure-temperature diagram

Accessories

- Screw joints for connection of the control line 3/8" to the filler neck. Other screw joints are available on request.
- Condensation chamber for steam condensation and protection of the operating diaphragm against extreme temperatures. This chamber is necessary for steam and liquids above 300 °F (150 °C).
- Control line kit - optionally with or without condensation chamber - for direct attachment to the valve and actuator (pressure tapped directly at the valve body, for set points ≥ 10 psi (≥ 0.8 bar)).

Detailed information on accessories can be found in Data Sheet T 2595 EN.

Ordering text

- Universal Pressure Reducing Valve **Type 41-23**
- Extended version ...
- Nominal size NPS (DN) ...
- Body material ..., Class (PN) ...
- C_v coefficient (K_{vS}) ...
- Set point range ... psi (bar)
- Optionally, accessories ...
- Optionally, special version ...

Specifications subject to change without notice.

